

# Monogamy of entanglement and mean-field ansatz for spin lattices

Ralf Schützhold

Fakultät für Physik

Universität Duisburg-Essen

UNIVERSITÄT  
DUISBURG  
ESSEN

# Spin Lattice

Regular lattice of 1/2-spins (qubits)

Pauli matrices  $\hat{\sigma}_\mu = (\hat{\sigma}_\mu^x, \hat{\sigma}_\mu^y, \hat{\sigma}_\mu^z)$

Coordination number  $Z$  (neighbours)

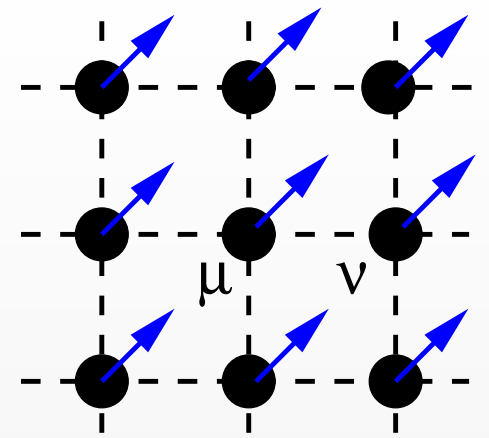

$$\hat{H} = \frac{1}{Z} \sum_{\langle \mu, \nu \rangle} \hat{\sigma}_\mu \cdot \mathbf{J} \cdot \hat{\sigma}_\nu + \sum_{\mu} \mathbf{B} \cdot \hat{\sigma}_\mu$$

In general very complicated  $\rightarrow$  mean-field ansatz

$$|\Psi_{\text{mf}}\rangle = \bigotimes_{\mu} |\psi_{\mu}\rangle, \quad \text{e.g.,} \quad |\Psi_{\text{mf}}\rangle = |\uparrow\rangle |\uparrow\rangle |\uparrow\rangle |\uparrow\rangle \dots$$

Variational mean-field energy per lattice site

$$\frac{\langle \hat{H} \rangle_{\text{mf}}}{N} = \frac{1}{2} \langle \hat{\sigma}_\mu \rangle \cdot \mathbf{J} \cdot \langle \hat{\sigma}_\nu \rangle + \mathbf{B} \cdot \langle \hat{\sigma}_\mu \rangle$$

Neglect of entanglement!?

# Entanglement for Pure States

Consider two spins (qubits)  $\mu$  and  $\nu$ : not entangled iff

$$|\Psi_{\mu\nu}\rangle = |\psi_\mu\rangle |\psi_\nu\rangle, \text{ e.g., } \frac{|\uparrow\rangle_\mu + |\downarrow\rangle_\mu}{\sqrt{2}} \frac{|\uparrow\rangle_\nu + |\downarrow\rangle_\nu}{\sqrt{2}}$$

Maximum entanglement (Bell state)

$$|\Psi_{\mu\nu}\rangle = \frac{|\uparrow\rangle_\mu |\uparrow\rangle_\mu + |\downarrow\rangle_\nu |\downarrow\rangle_\nu}{\sqrt{2}} = |\text{Bell}\rangle_{\mu\nu}$$

General state with concurrence  $C$  with  $0 \leq C \leq 1$

$$|\Psi_{\mu\nu}\rangle = \sqrt{1-C} |\psi_\mu\rangle |\psi_\nu\rangle + \sqrt{C} \hat{U}_\mu \hat{U}_\nu |\text{Bell}\rangle_{\mu\nu}$$

W.K. Wothers, Phys. Rev. Lett. **80**, 2245 (1998).

Note: qutrits or three qubits are more complicated

$$|\Psi_{\text{GHZ}}\rangle = \frac{|\uparrow\rangle |\uparrow\rangle |\uparrow\rangle + |\downarrow\rangle |\downarrow\rangle |\downarrow\rangle}{\sqrt{2}}$$

# Mixed State of Two Spins

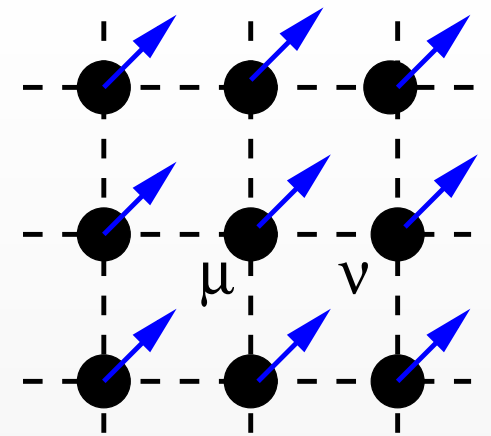

General decomposition (not unique)

$$\hat{\rho}_{\langle\mu\nu\rangle} = \sum_I p_I |\Psi_{\mu\nu}^I\rangle \langle\Psi_{\mu\nu}^I|$$

Problem: consider all possible decompositions

$$\text{ent}(\hat{\rho}_{\langle\mu\nu\rangle}) = \min_{p_I, |\Psi_{\mu\nu}^I\rangle} \sum_I p_I \text{ent}(|\Psi_{\mu\nu}^I\rangle \langle\Psi_{\mu\nu}^I|)$$

Problem solved for concurrence  $C(\hat{\rho}_{\langle\mu\nu\rangle})$  (2 qubits)

W.K. Wothers, Phys. Rev. Lett. **80**, 2245 (1998); A. Uhlmann, Phys. Rev. A **62**, 022307 (2000).

Symmetric decomposition for general mixed states

$$\hat{\rho}_{\langle\mu\nu\rangle} = \sum_{I=1}^4 p_I |\Psi_{\mu\nu}^I\rangle \langle\Psi_{\mu\nu}^I| : C(\hat{\rho}_{\langle\mu\nu\rangle}) = C(|\Psi_{\mu\nu}^I\rangle \langle\Psi_{\mu\nu}^I|) \quad \forall I$$

Again: for 2 qubits only...

# Monogamy of Entanglement

Upper bound for concurrence of qubit-pairs

$$\tau_1(\hat{\rho}_\mu) = 4 \det(\hat{\rho}_\mu) \geq \sum_\nu C^2(\hat{\rho}_{\langle \mu\nu \rangle})$$

with one-tangle  $\tau_1(\hat{\rho}_\mu) \leq 1$

V. Coffman, J. Kundu, W.K. Wootters, Phys. Rev. A **61**, 052306 (2000);

T.J. Osborne, F. Verstraete, Phys. Rev. Lett. **96**, 220503 (2006).

Lattice isotropy

$$C(\hat{\rho}_{\langle \mu\nu \rangle}) \leq \sqrt{\frac{\tau_1}{Z}} \leq \sqrt{\frac{1}{Z}}$$

Entanglement decreases for large  $Z$

Expectation: mean-field ansatz becomes better

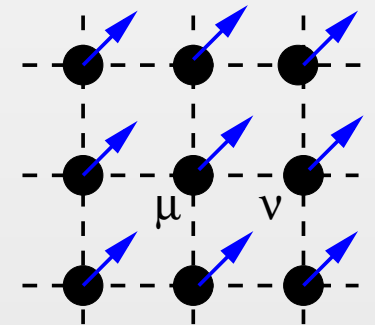
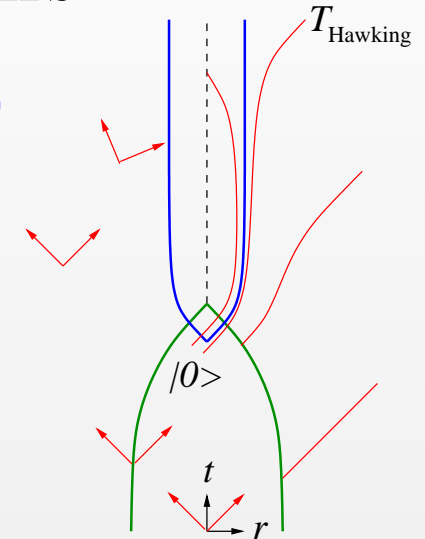

# Ground State Energy

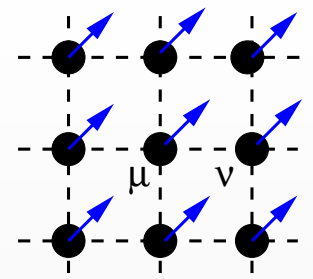

$$\hat{H} = \frac{1}{Z} \sum_{\langle \mu, \nu \rangle} \hat{\sigma}_{\mu} \cdot \mathbf{J} \cdot \hat{\sigma}_{\nu} + \sum_{\mu} \mathbf{B} \cdot \hat{\sigma}_{\mu}$$

Insert  $\hat{\rho}_{\langle \mu \nu \rangle} = \sum_{I=1}^4 p_I |\Psi_{\mu\nu}^I\rangle \langle \Psi_{\mu\nu}^I|$  with

$$|\Psi_{\mu\nu}^I\rangle = \sqrt{1-C} |\psi_{\mu}^I\rangle |\psi_{\nu}^I\rangle + \sqrt{C} \hat{U}_{\mu}^I \hat{U}_{\nu}^I |\text{Bell}\rangle_{\mu\nu}$$

→ estimate for ground-state energy

$$\frac{\langle \hat{H} \rangle}{N} = \sum_{I=1}^4 \frac{p_I}{2} \left[ \langle \hat{\sigma}_{\mu}^I \rangle \cdot \mathbf{J} \cdot \langle \hat{\sigma}_{\nu}^I \rangle + \mathbf{B} \cdot (\langle \hat{\sigma}_{\mu}^I \rangle + \langle \hat{\sigma}_{\nu}^I \rangle) \right] + \mathcal{O}(\sqrt{C})$$

with  $\langle \hat{\sigma}_{\mu}^I \rangle = \langle \psi_{\mu}^I | \hat{\sigma}_{\mu} | \psi_{\mu}^I \rangle$  → mean-field ansatz

Ergo:  $Z \gg 1 \rightarrow C \ll 1 \rightarrow$  mean-field behaviour

# Intermediate Summary

Concurrence  $C$  measures deviation from mean-field

$$\frac{\langle \hat{H} \rangle_{\text{mf}}}{N} - \frac{\langle \hat{H} \rangle_{\text{exact}}}{N} \leq (||\mathbf{J}|| + 2||\mathbf{B}||)\sqrt{C} + \mathcal{O}(C)$$

→  $C = 0$  only if mean-field yields exact ground state

Large  $Z \gg 1 \rightarrow$  small  $C \leq 1/\sqrt{Z} \ll 1$

→ mean-field becomes better for large  $Z \gg 1$

Note: different from quantum de Finetti theorem  
(full permutational invariance vs lattice symmetry)

E.g., Lipkin-Meshkov-Glick model

$$\hat{H} = \frac{1}{N} \sum_{\mu, \nu} \hat{\sigma}_{\mu} \cdot \mathbf{J} \cdot \hat{\sigma}_{\nu} + \sum_{\mu} \mathbf{B} \cdot \hat{\sigma}_{\mu}$$

→ large spin  $\Sigma = \sum_{\mu} \hat{\sigma}_{\mu} / N$

# Example: Ising Model

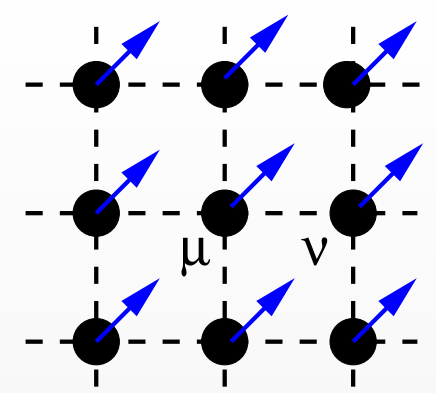

$$\hat{H} = -\frac{J}{Z} \sum_{\langle \mu, \nu \rangle} \hat{\sigma}_{\mu}^x \hat{\sigma}_{\nu}^x - B \sum_{\mu} \hat{\sigma}_{\mu}^z$$

Mean-field ansatz: paramagnetic for  $B > |J|$

$$|\Psi_{\text{mf}}\rangle = |\uparrow\uparrow\uparrow \dots\rangle$$

Estimate for exact on-site density matrix

$$\hat{\rho}_{\mu} = |\uparrow\rangle \langle\uparrow| + \mathcal{O}(\sqrt{C}) = |\uparrow\rangle \langle\uparrow| + \mathcal{O}(1/Z^{1/4})$$

→ iterate monogamy argument  $C \leq \sqrt{\tau_1/Z}$

$$C \leq \mathcal{O}(Z^{-2/3}), \quad \tau_1 = 4 \det(\hat{\rho}_{\mu}) \leq \mathcal{O}(Z^{-1/3})$$

Hierarchy of correlations suggests

$$C = \mathcal{O}(1/Z), \quad \tau_1 = \mathcal{O}(1/Z)$$

P. Navez, F. Queisser, R.S., J. Phys. A **47**,225004 (2014).



# Improved Mean-Field Ansatz

Idea: add a little bit of entanglement for 2 spins

$$|\Psi_{\mu\nu}\rangle = \mathcal{N} (1 + \hat{\sigma}_{\mu} \cdot \xi \cdot \hat{\sigma}_{\nu}) |\uparrow\rangle_{\mu} |\uparrow\rangle_{\nu}$$

Generalisation to spin lattices

$$|\Psi\rangle_{\text{imf}} = \mathcal{N} \left( \prod_{\langle\mu,\nu\rangle} \exp \{ \xi \hat{\sigma}_{\mu}^x \hat{\sigma}_{\nu}^x \} \right) \bigotimes_{\mu} |\uparrow\rangle_{\mu} ,$$

Variational ansatz

$$\frac{\langle \hat{H} \rangle_{\text{imf}}}{N} = -\frac{J}{2} \tanh(2\Re\xi) - B \left( \frac{\cos(2\Im\xi)}{\cosh(2\Re\xi)} \right)^Z$$

Energy minimum for

$$\xi_{\text{min}} = \frac{J}{4BZ} + \mathcal{O}(1/Z^2) \rightsquigarrow C = \mathcal{O}(1/Z)$$

# XY-Model

$$\hat{H} = -\frac{J}{Z} \sum_{\langle \mu, \nu \rangle} \left( \frac{1 + \gamma}{2} \hat{\sigma}_{\mu}^x \hat{\sigma}_{\nu}^x + \frac{1 - \gamma}{2} \hat{\sigma}_{\mu}^y \hat{\sigma}_{\nu}^y \right) - B \sum_{\mu} \hat{\sigma}_{\mu}^z$$

Scaling with anisotropy parameter  $\gamma$

$$\xi_{\min} = \gamma \frac{J}{4BZ} + \mathcal{O}(1/Z^2)$$

Scaling variable  $\zeta = Z|\xi|$

$$C = 2 \frac{\zeta - \zeta^2}{Z} \Theta(1 - \zeta) + \mathcal{O}(1/Z^2)$$

→  $\xi_{\min}$  and  $C$  vanish in isotropic limit  $\gamma = 0$

$$|\Psi_{\text{imf}}\rangle = |\Psi_{\text{mf}}\rangle = |\uparrow\uparrow\uparrow \dots\rangle$$

↔ paramagnetic state is exact for  $B > |J|$

# Conclusions & Outlook

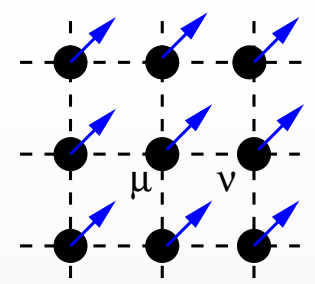

Concurrence  $C$  measures deviation from mean-field

$$\frac{\langle \hat{H} \rangle_{\text{mf}}}{N} - \frac{\langle \hat{H} \rangle_{\text{exact}}}{N} \leq (||\mathbf{J}|| + 2||\mathbf{B}||)\sqrt{C} + \mathcal{O}(C)$$

- $C = 0 \leftrightarrow$  mean-field yields exact ground state
- monogamy:  $Z \gg 1 \rightarrow C \leq 1/\sqrt{Z} \ll 1$
- unique mean-field ground state:  $C = \mathcal{O}(Z^{-2/3})$
- improved mean-field ansatz:  $C = \mathcal{O}(1/Z)$   
(note: not rigorously proven)

Outlook: bi-partite  $\rightarrow$  tri-partite entanglement...

A. Osterloh, R.S., [arXiv:1406.0311](https://arxiv.org/abs/1406.0311)