



The High Altitude Water Cherenkov (HAWC) TeV Gamma-Ray Observatory

**Eduardo de la Fuente Acosta
for the HAWC Collaboration**

**Universidad de Guadalajara, CUCEI, México
edfuente@gmail.com**



**Supernova and Gamma Ray Burst, 2013, Yukawa Institute for Theoretical Physics,
University of Kyoto, Octubre-November, 2013**



Outline

I.- INTRODUCTION

II.- GAMMA RAYS REMARKS

III.- MILAGRO OBSERVATORY: THE FIRST GENERATION OF WATER CHERENKOV DETECTORS (WCD)

IV.- HIGH ALTITUDE WATER CERENKOV (HAWC); THE SECOND GENERATION OF WCD

V.- HAWC (DESIGN, COLABORATION, ELECTRONICS, DATES, PERFORMANCE, SCIENTIFIC CASE)

VI.- FIRST LIGHT AND PRELIMINARY RESULTS

VII.- FUTURE

I.- INTRODUCTION

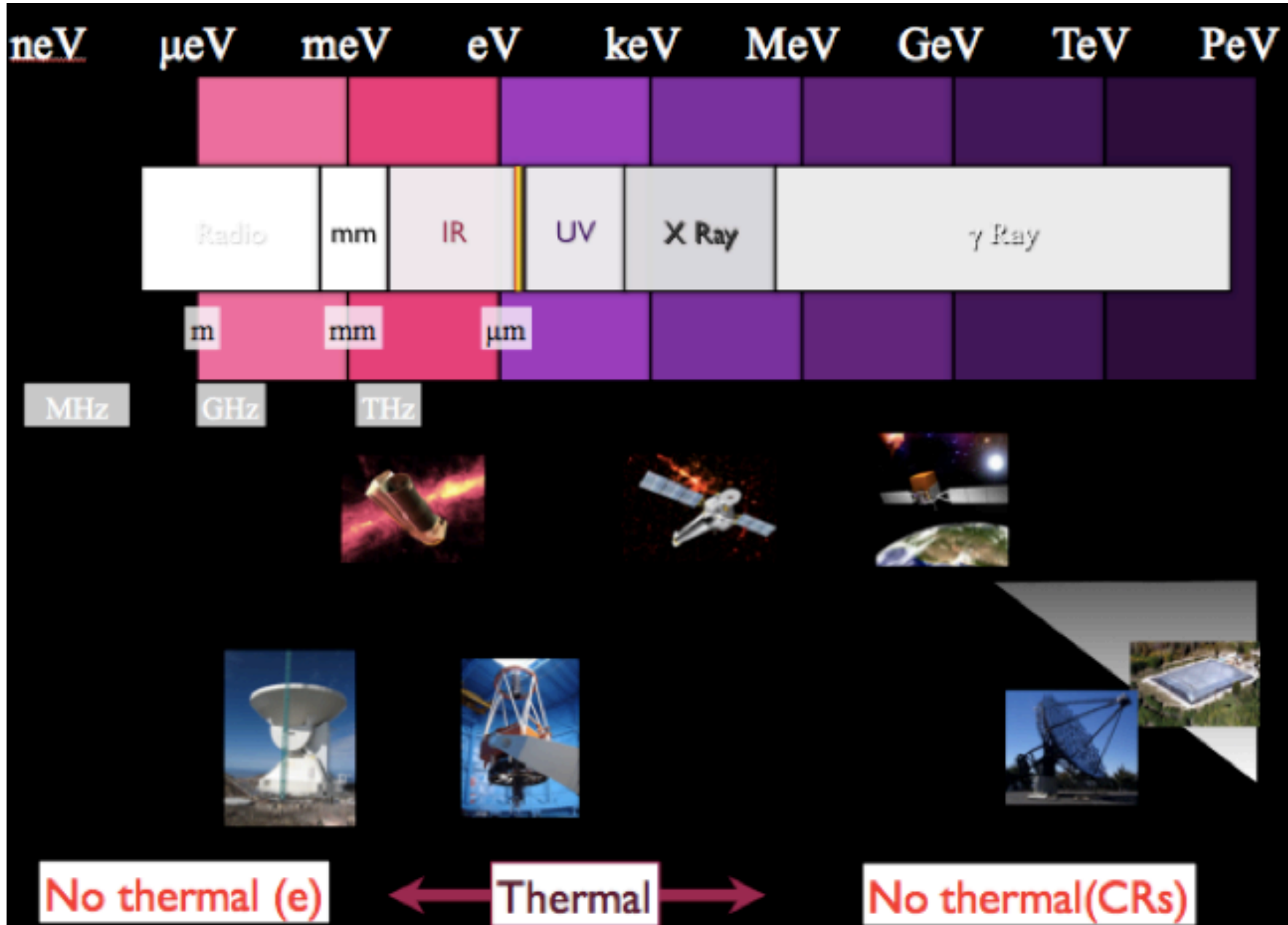

I.- INTRODUCTION

Wide Field of View, Continuous Operations

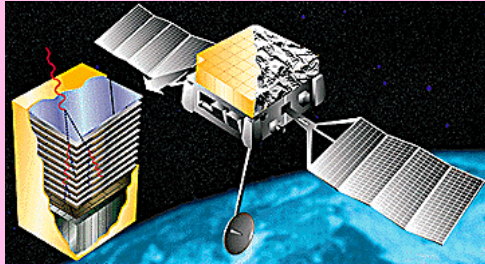

FERMI, AGILE, EGRET

Satellite Experiments

- high **duty cycle** ≈ 100 %
- large **sky coverage** LAT: ≈ 20 %
- sensitive to **medium energies** LAT: ≈ 30 MeV – 300 GeV

TeV Sensitivity



HAWC
ARGO
Milagro
Tibet ASy



VERITAS
HESS
MAGIC

I.- INTRODUCTION

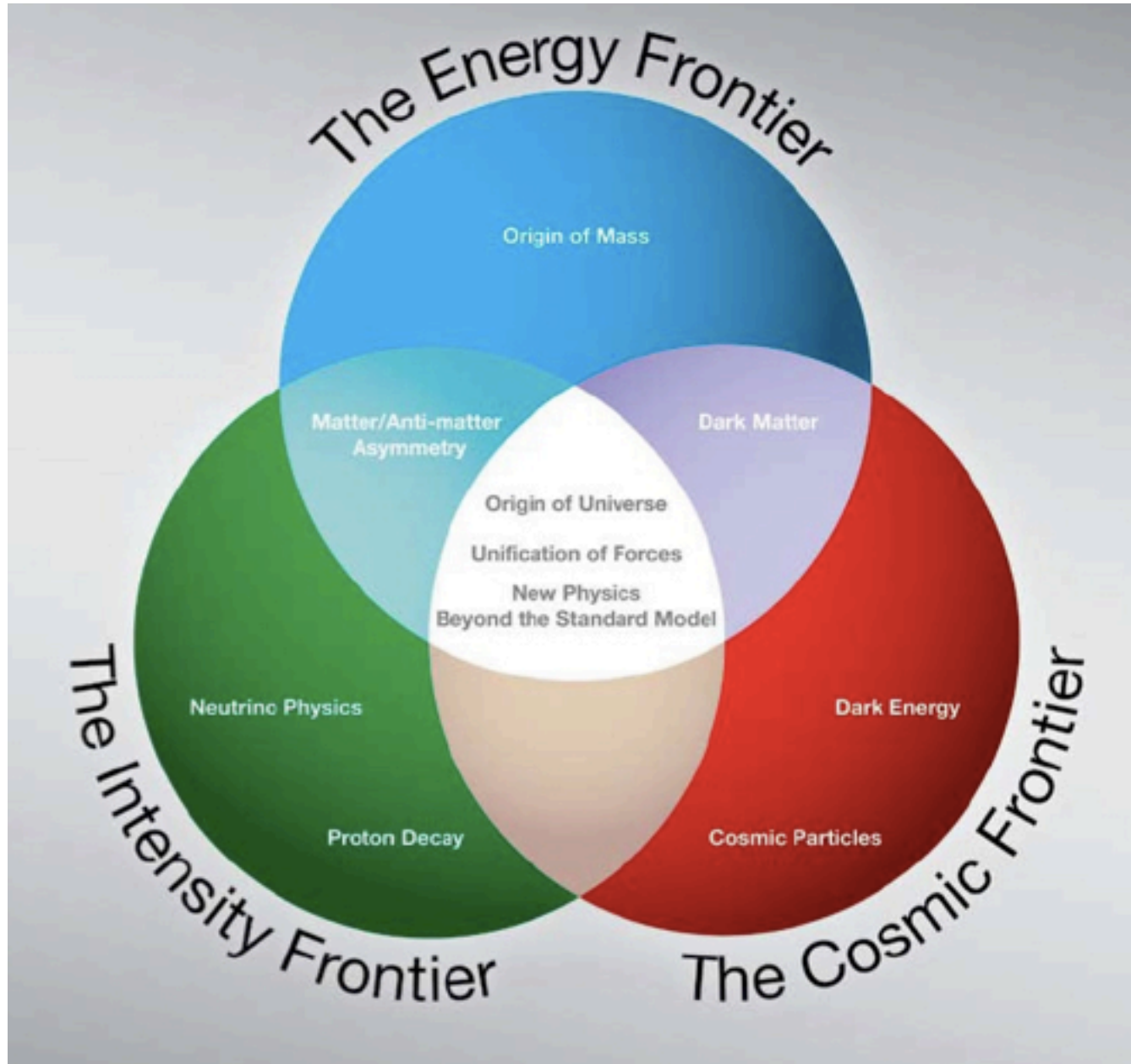

By interaction with matter

π^0 – decay:

In hadronic interactions produced neutral pions decay

Immediately: $\pi^0 \rightarrow \gamma + \gamma$ ($\tau = 8.4 \cdot 10^{-17}$ s)

Electron - Bremsstrahlung:

Deflected electrons in the coulomb field of nuclei emit radiation with the probability

$$\phi \propto z^2 Z^2 E_e / m^2$$

Annihilation and radioactive decay:

In dense matter annihilate electron-positron (proton-antiproton) pairs

$$e^+ + e^- \rightarrow \gamma + \gamma \quad (\rightarrow E_\gamma = 511 \text{ keV})$$

$$p + p^- \rightarrow \pi^+ + \pi^- + \pi^0$$

In elemental synthesis exist radioisotopes which have β – decay.

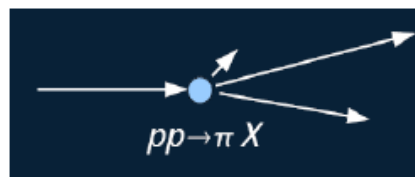

proton acceleration

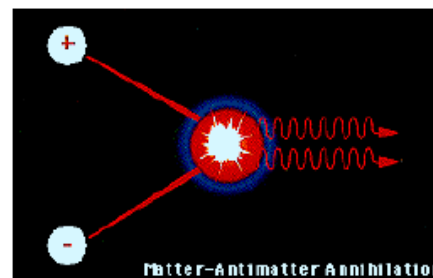
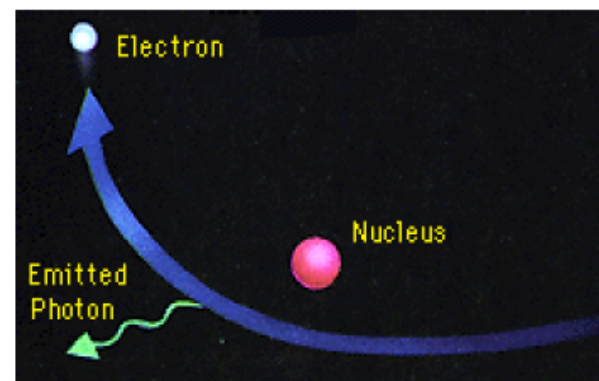
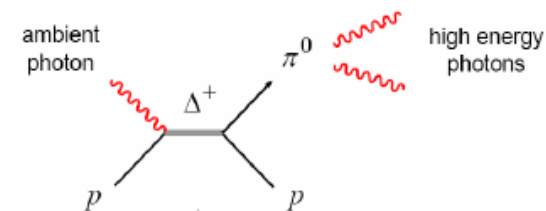

II.- Gamma Ray Emission Mechanism

By interaction with magnetic fields

Synchrotron radiation:

Radiation of accelerated charged particles (electrons) in magnetic fields.

Power of the radiation: $P \propto E_e^2 \cdot B^2$

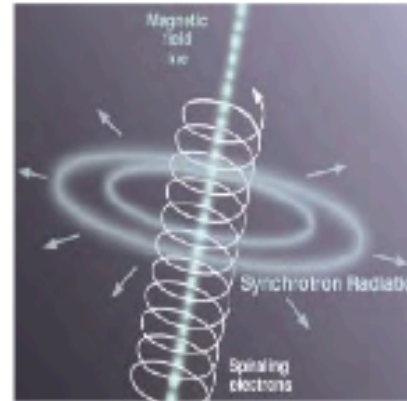

Synchrotron radiation



Inverse Compton scattering

By interaction with photon fields

Inverse compton scattering:

fast electrons transfer energy on low energy photons

→ Blue shifted photons

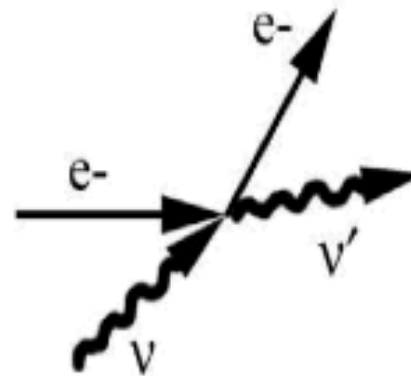

$$\nu' > \nu$$

High energy e- initially
e- loses energy

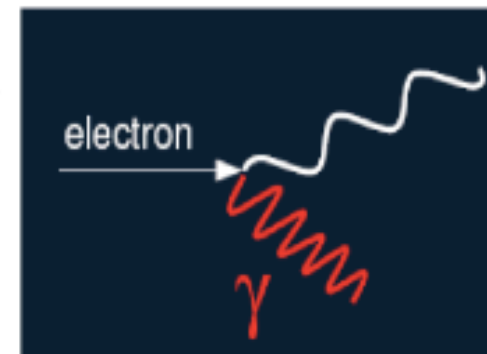

II.- Gamma Ray Probe Accelerated Particles⁷

Electrons:

Synchrotron Emission

- Probes Magnetic Field, Electron Energy

Inverse Compton Scattering

- Probes Photon Field, Electron Energy

Synchrotron Self Compton

- If photon field is synchrotron, then Electron Energies & Magnetic Field are determined
- Quadratic relation between variability of TeV (IC) and X-rays (synch)

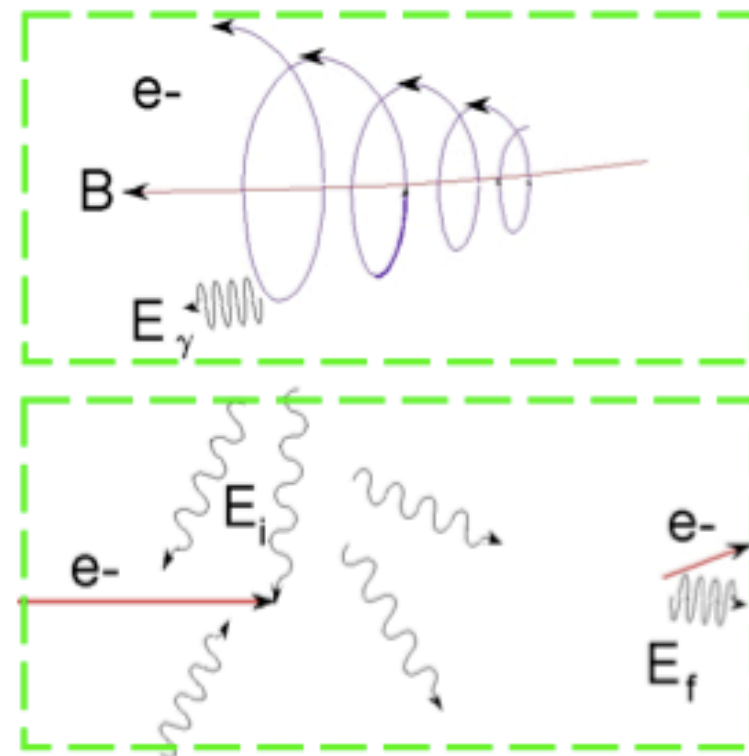

Hadrons:



II.- Gamma Ray Observations on Earth ?

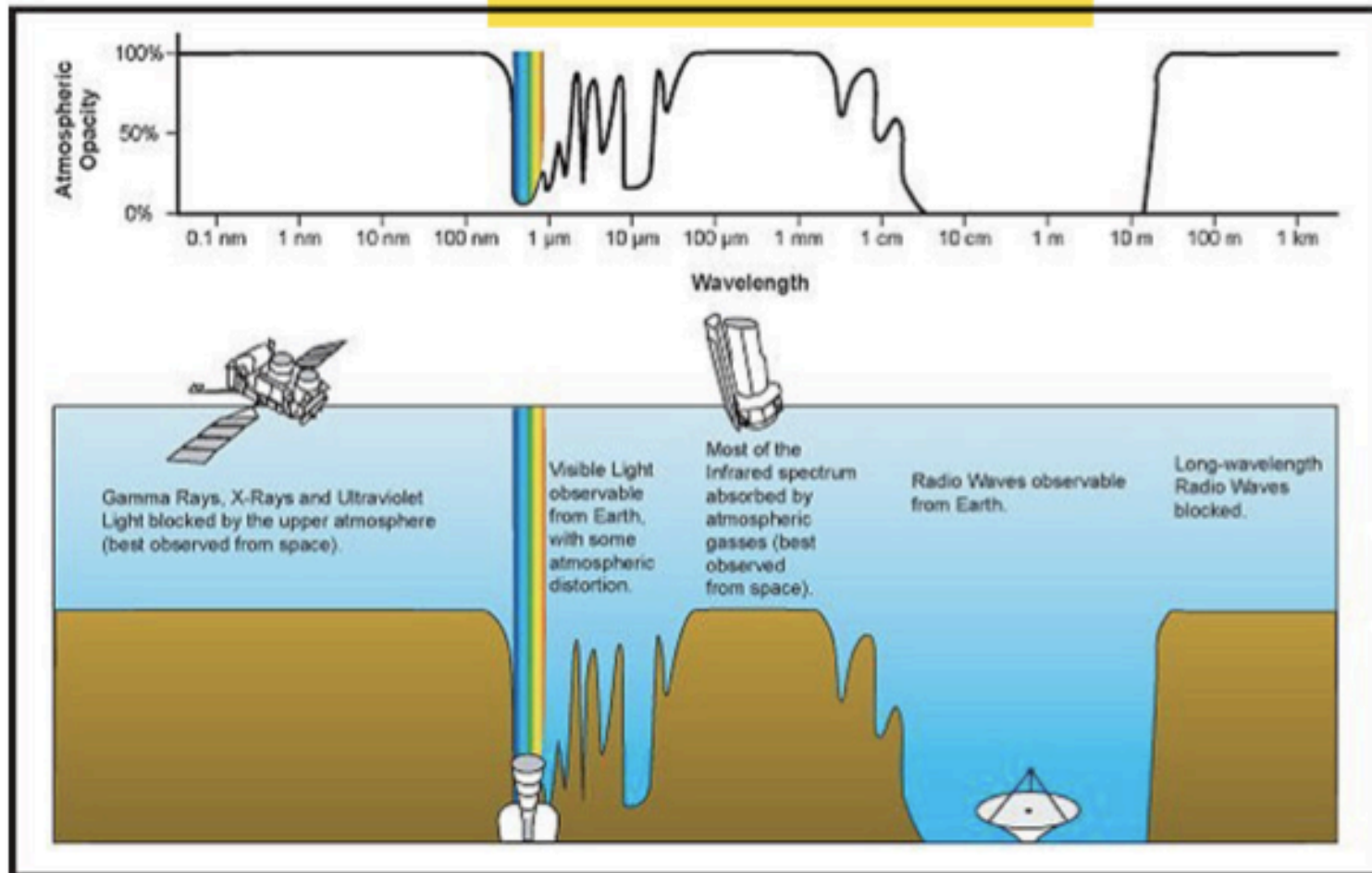
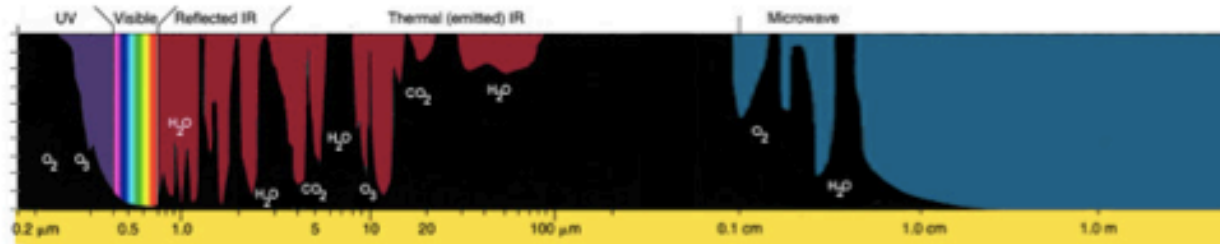

II.- Gamma Ray Observations on Earth ?

YES

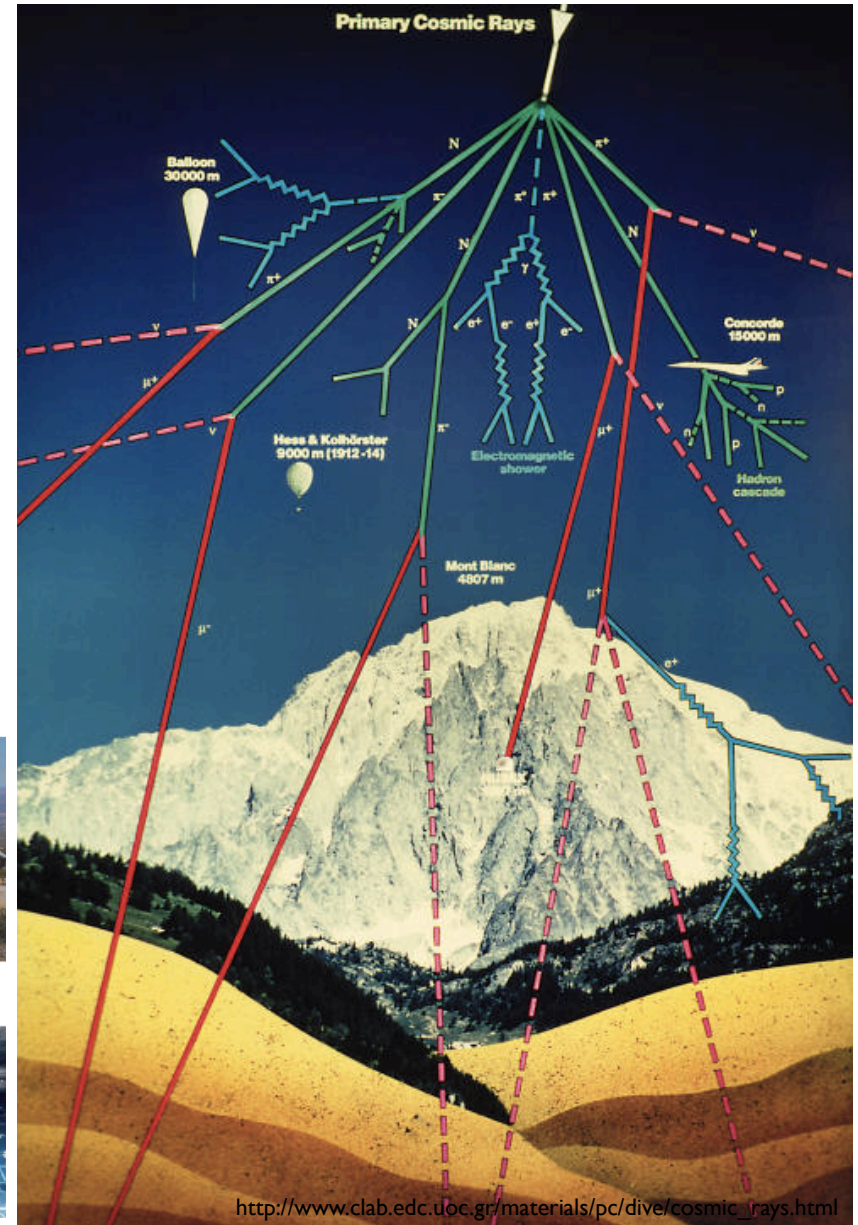
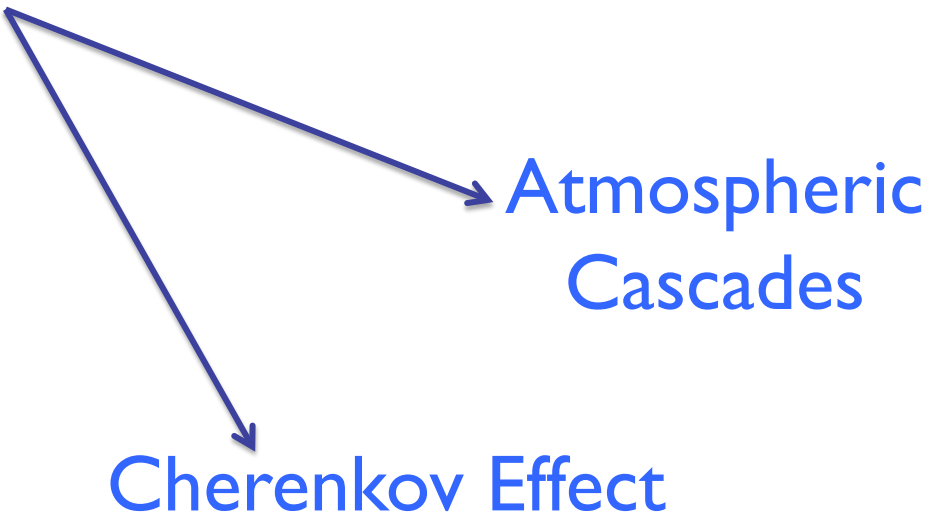

Air Cherenkov Telescopes

- very good **angular resolution** $\lesssim 0.2^\circ$
- large **effective area** $O(10^5 \text{ m}^2)$
- sensitive to very **high energies** $\approx 100 \text{ GeV} - 50 \text{ TeV}$



Water Cherenkov Detectors

- high **duty cycle** $\approx 95\%$
- large **effective area** $O(10^4 \text{ m}^2)$
- sensitive to very **high energies**

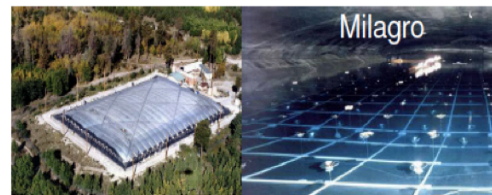

II.- Gamma Ray Observations on Earth ? Atmospheric cascade

Prior to shower maximum:

- Exponential growth in particle.
- Energy \rightarrow particle creation (pair, brems.)

After shower maximum:

- Exponential decay in particle number.
- Particle energies fall below E_{Critical} ($\sigma_{\text{Compton}} > \sigma_{\text{Pair}}$).
- Particle spectrum is independent of elevation.
- Energy deposited in atmosphere through ionization.
- For a 1 TeV shower, 100 GeV reaches HAWC observation level.

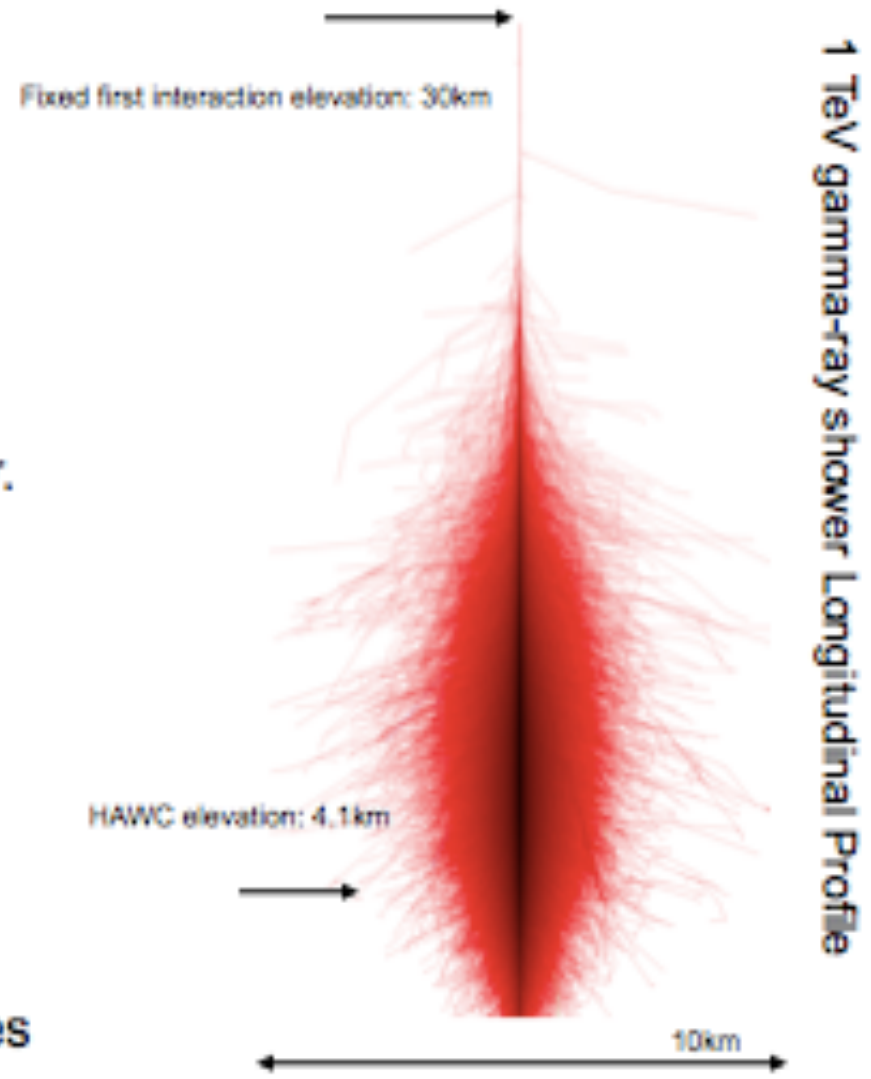

From <http://www.ast.leeds.ac.uk/~fs/photons-showers.html>

Atmospheric cascade components (Gamma rays, Cosmic rays, Neutrons):

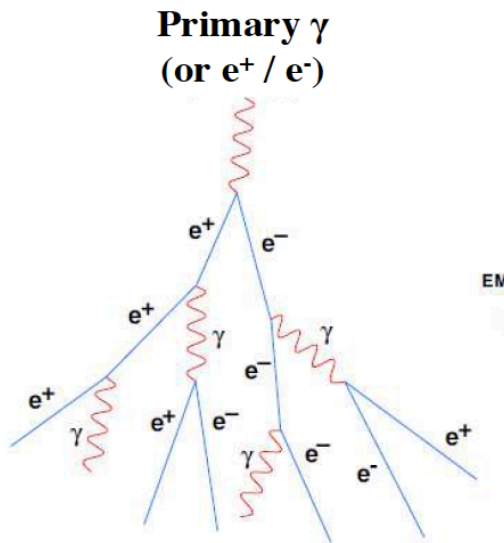

Pure electromagnetic Cascade

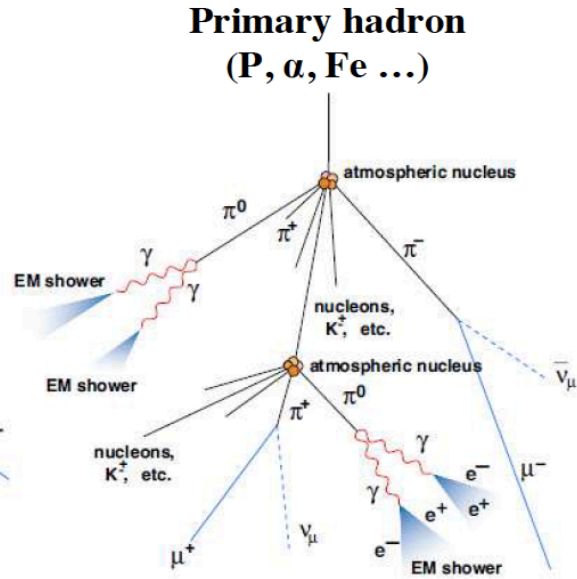

Hadronic Cascade:
 • 1/3 electromagnetic (π^0)
 • 2/3 "lost" ($\pi^\pm \rightarrow \mu^\pm + \nu$)

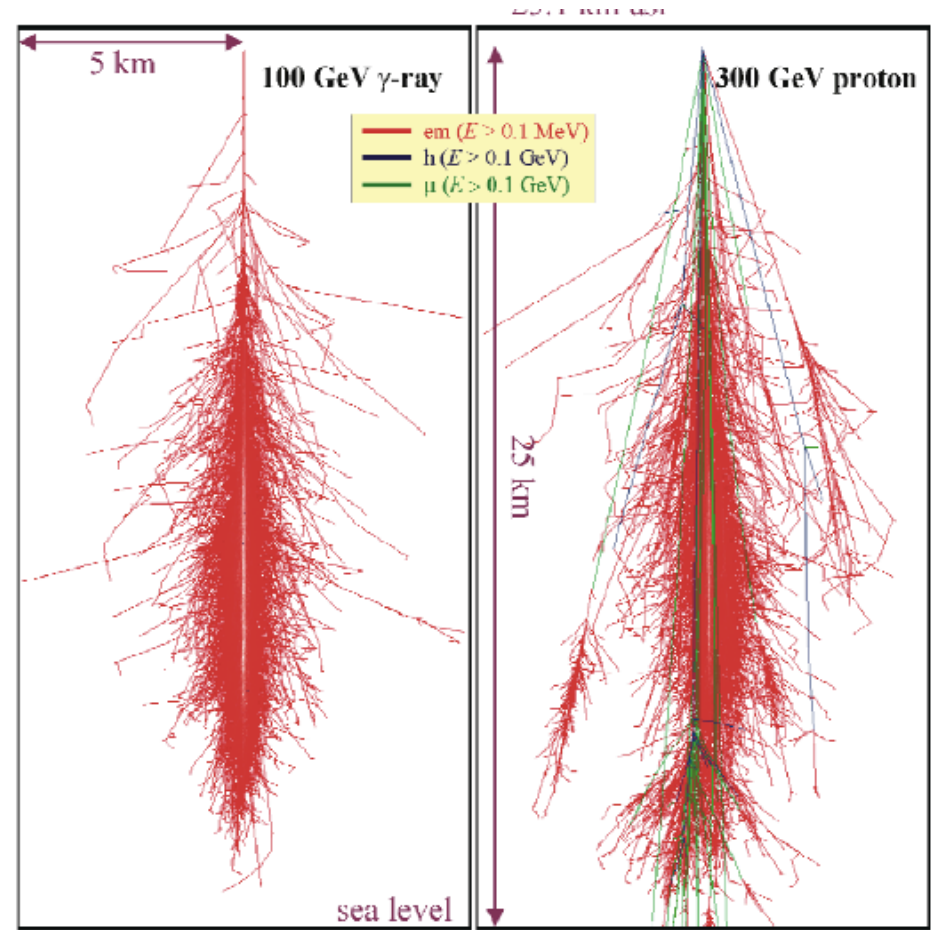

Hadronic Component dominates in emission over the Electromagnetic Component, therefore for gamma rays observations, a good Gamma/Hadron rejection is needed

II.- Gamma Ray Observations on Earth ?

Cherenkov Effect

- In a material with refractive index, n , a charged particle emits if its velocity is greater than the local phase velocity of light .
- The charged particle polarizes the atoms along its trajectory
- These time dependent dipole emit electromagnetic radiation
- If $v < c / n$, the dipole distribution is symmetric around the particle position, and the sum of all dipoles vanishes
- If $v > c / n$, the distribution is asymmetric and the total time dependent dipole is not null, thus radiates.

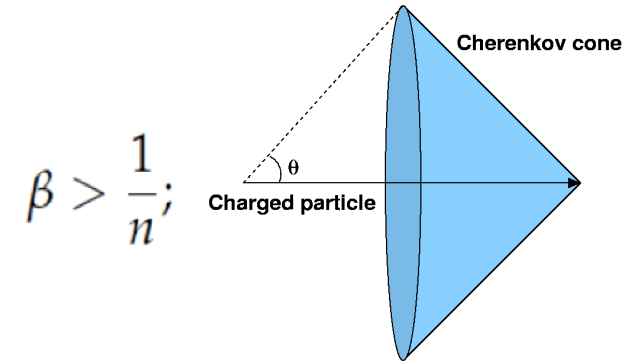

$$\beta > \frac{1}{n};$$

$$\frac{d^2\mathcal{E}_\omega}{d\omega dz} \propto \omega; \quad \text{Shorter wavelengths, more intense}$$

Frank-Tamm Theory (1937, Nobel 1950)

$$\frac{dE}{dl} = \frac{2\pi e^2 \nu}{c^2} \left[1 - \frac{1}{\beta^2 n^2(\nu)} \right]$$

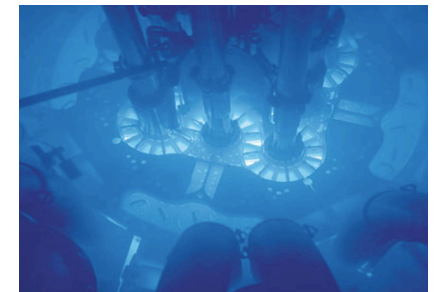

II.- Gamma Ray Observations on Earth ?

Air Cherenkov Detectors

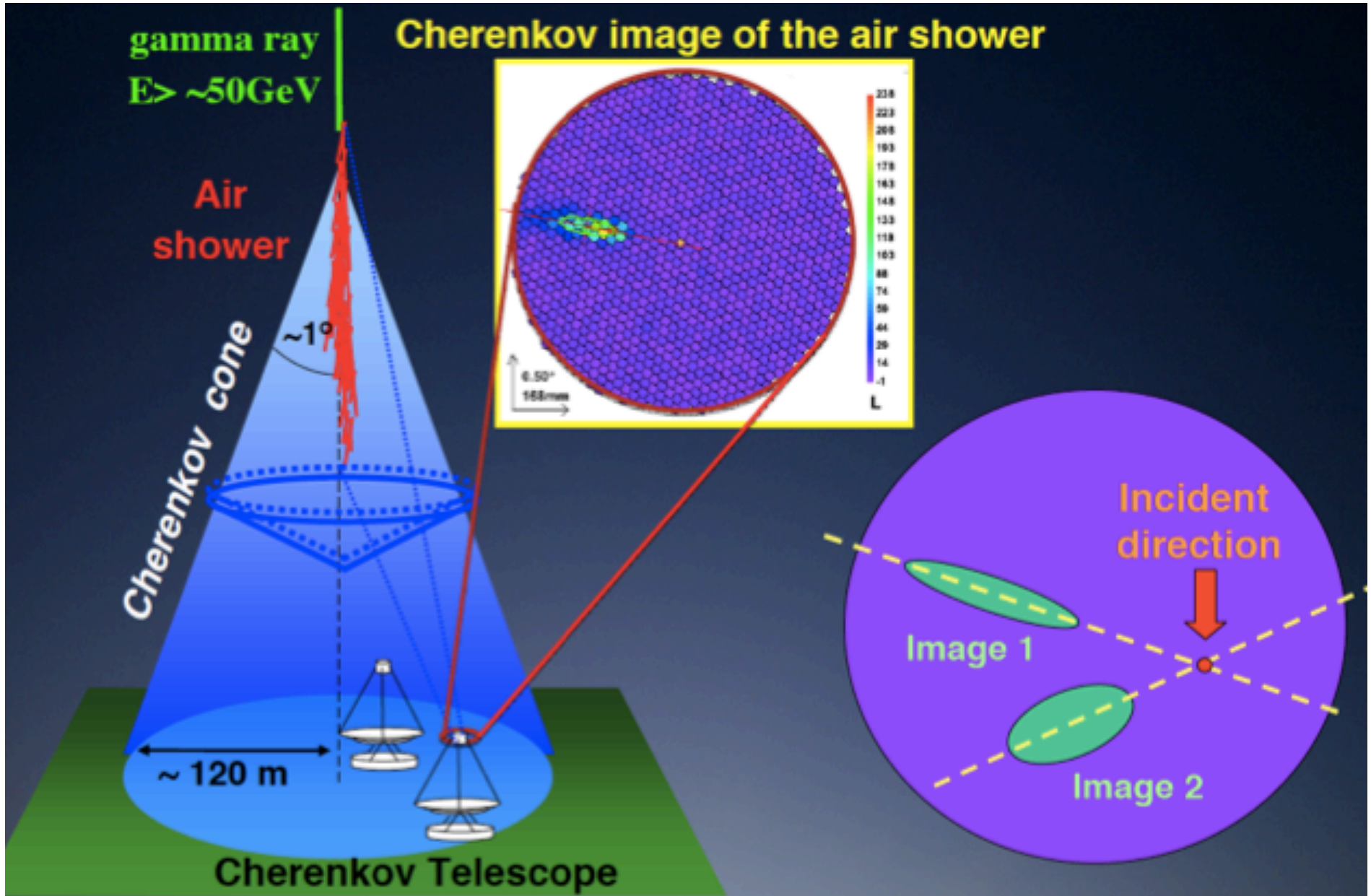

II.- Gamma Ray Observations on Earth ?

Water Cherenkov Detectors

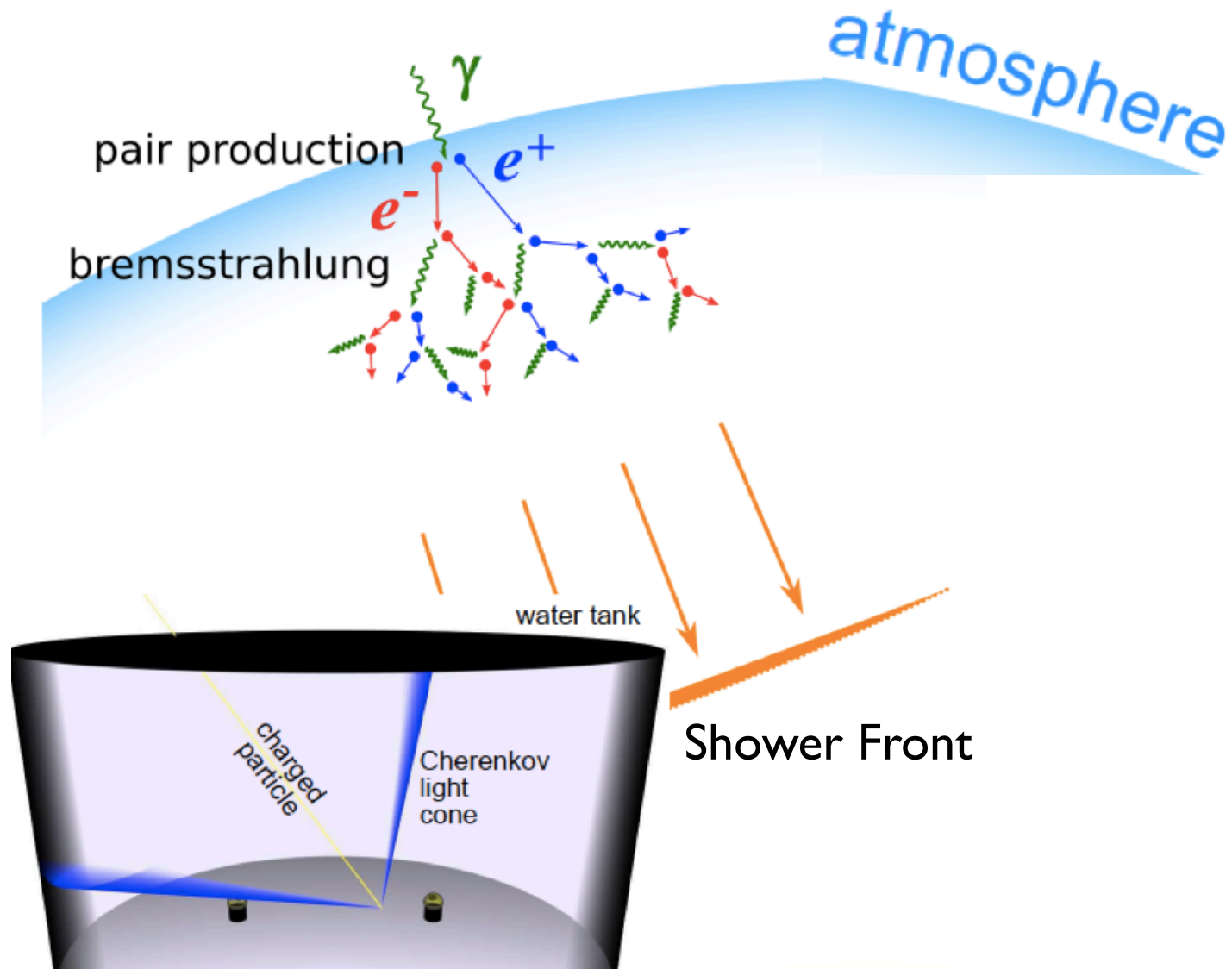

III.- First Generation on WCD

MILAGRO

- 2600M ASL (NM, USA)
- 2000-2008
- WATER CHERENKOV DETECTOR
- 898 PMTs
 - 450 TOP/273 BOTTOM
 - 175 OUTRIGGERS
- 40,000M² AREA
- 1700 HZ TRIGGER RATE
- 0.4°-0.9° RESOLUTION
- 2-40 TEV MEDIAN ENERGY









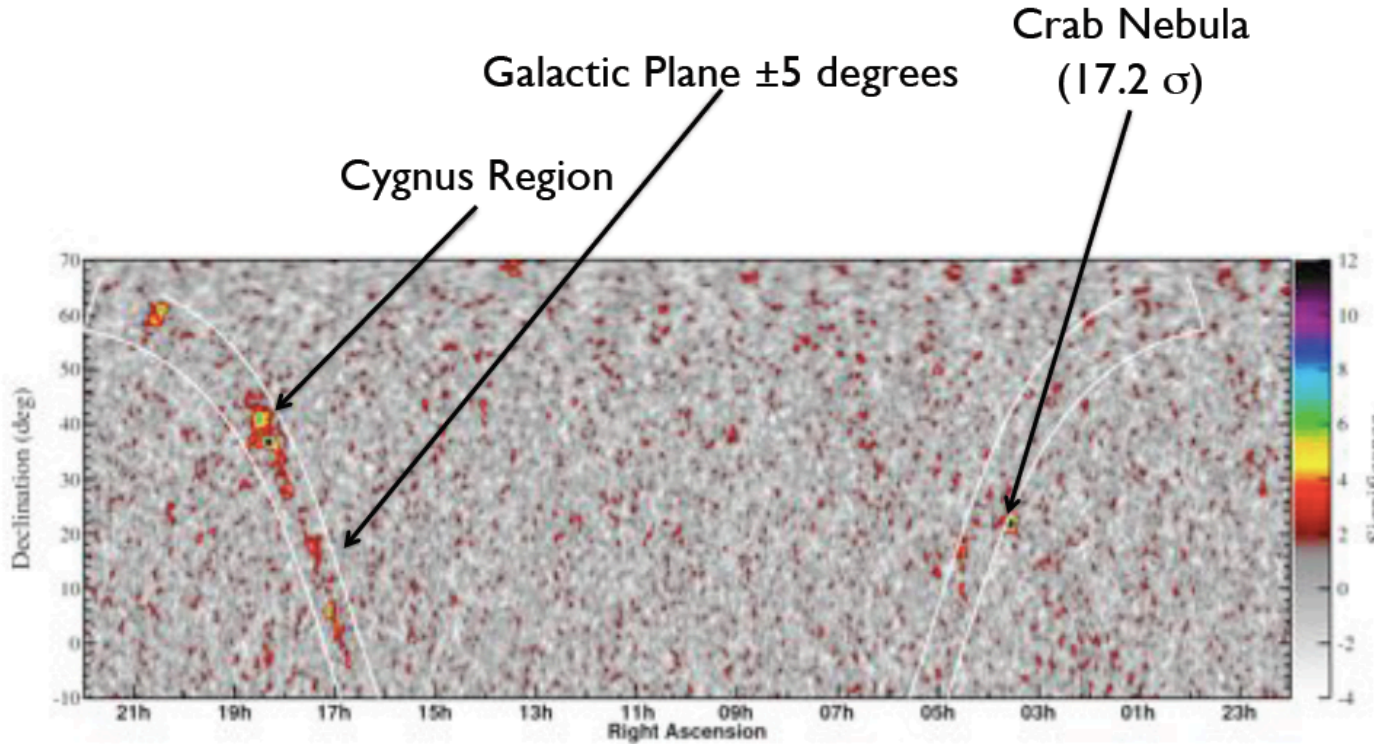

See **MILAGRO** (LANL; 60 x 80 x 8 m; Abdo et al., 2007, 2009, for details).
 Threshold: 500 GeV. 6.5 years of data (Jul 2000 – Jan 2007); crab nebula 15 sigmas, GP clearly visible

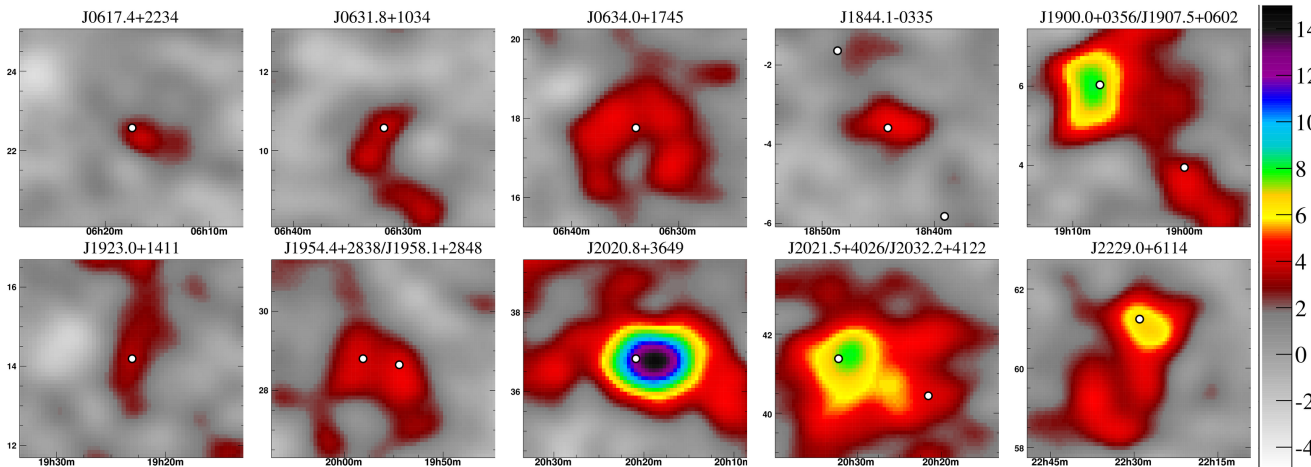

Abdo et al., ApJ Lett 2009

IV.- High Altitude Water Cherenkov (HAWC) Observatory: Second Generation (WCD)



15 times Milagro Sensitivity

Saddle point between Pico Orizaba (5636 m), and Sierra Negra (4640 m)
 Site: 4100m, 18°58'N 97°16'W. Central Mexico
 300 Water Tanks. 7.3 m (diam), 4.5 m deep. 22,000 m², 57% coverage

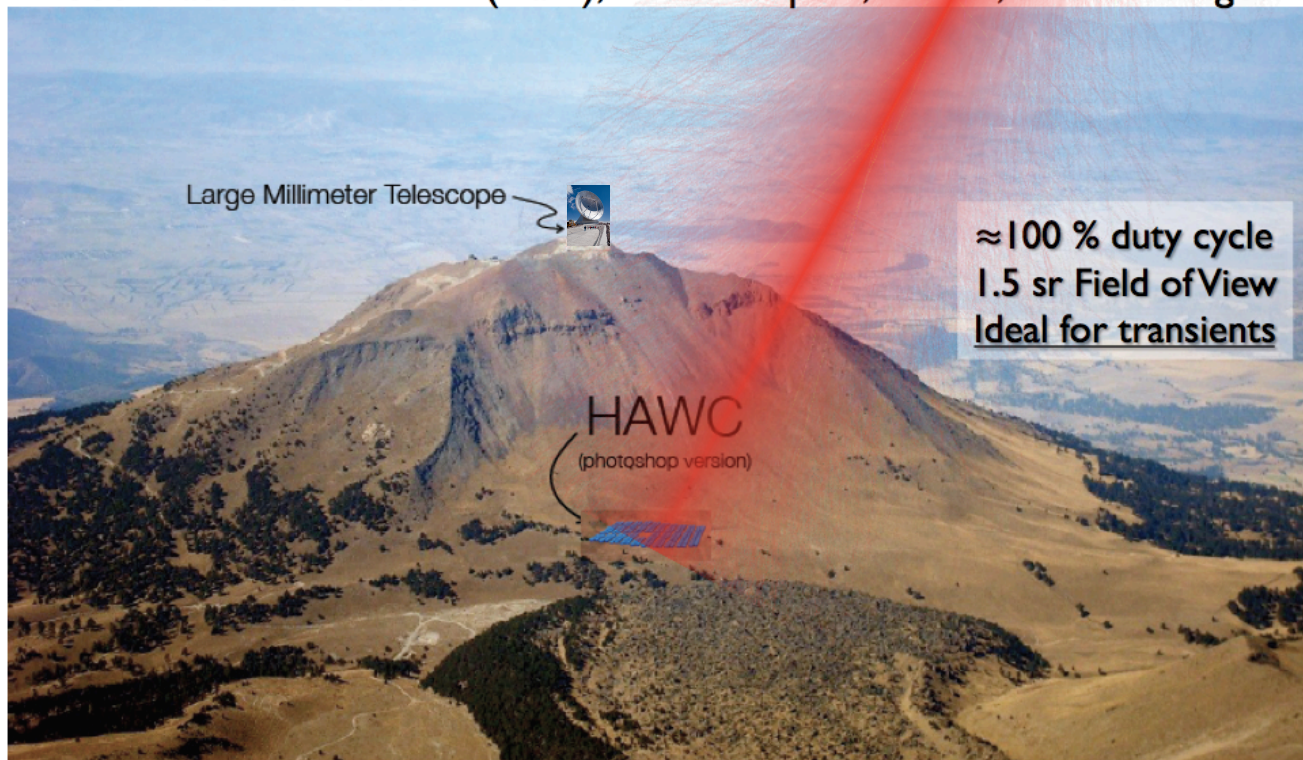

IV.- High Altitude Water Cherenkov (HAWC) Observatory: Second Generation (WCD)

High Altitude lowers energy threshold

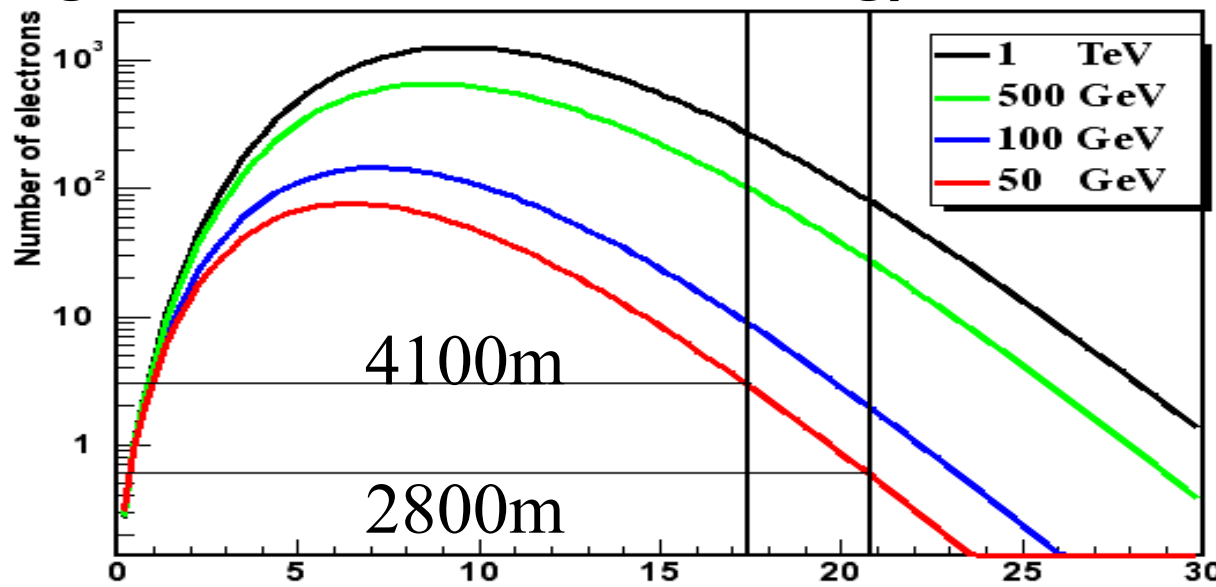

The scale length for the energy loss of e and photons when interacts with matter (gr cm-2)

- **Higher Altitude means fewer radiation lengths and more particles**
- **Fluctuations in first interaction means more particles**
- **For example 5% of events ($e^{-3}=5\%$) will have 5 x more particles**

IV.- High Altitude Water Cherenkov (HAWC) Observatory: Second Generation (WCD)

	Milagro	HAWC
Detector Area	3500 m ² /2100 m ²	20,000 m ²
Time to 5 σ on the Crab	120 days	5hrs
Median Energy	4 TeV	1 TeV
Angular Resolution	0.40 ^o – 0.75 ^o	0.25 ^o – 0.50 ^o
Energy Resolution at 5 TeV	140%	72%
Energy Resolution at 50 TeV	85%	35%
Hadron Rejection efficiency at 10 TeV	90%	>99.5%
Q for gamma/hadron rejection	1.6	5
Time to detect 5 Crab flare at 5 σ	5 days	10 minutes
Eff. Area at 100 GeV	5 m ²	100 m ²
Eff. Area at 1 TeV	10 ³ m ²	20x10 ³ m ²
Eff Area at 10 TeV	20x10 ³ m ²	50x10 ³ m ²
Eff Area at 50 TeV	70x10 ³ m ²	70x10 ³ m ²
Volume of Universe where 3x10 ⁻⁶ erg/cm ² GRB is detectable	7 Gpc ³	47 Gpc ³
Flux Sensitivity to a Crab-like source (1 year) (5 σ detection)	625 mCrab	45 mCrab

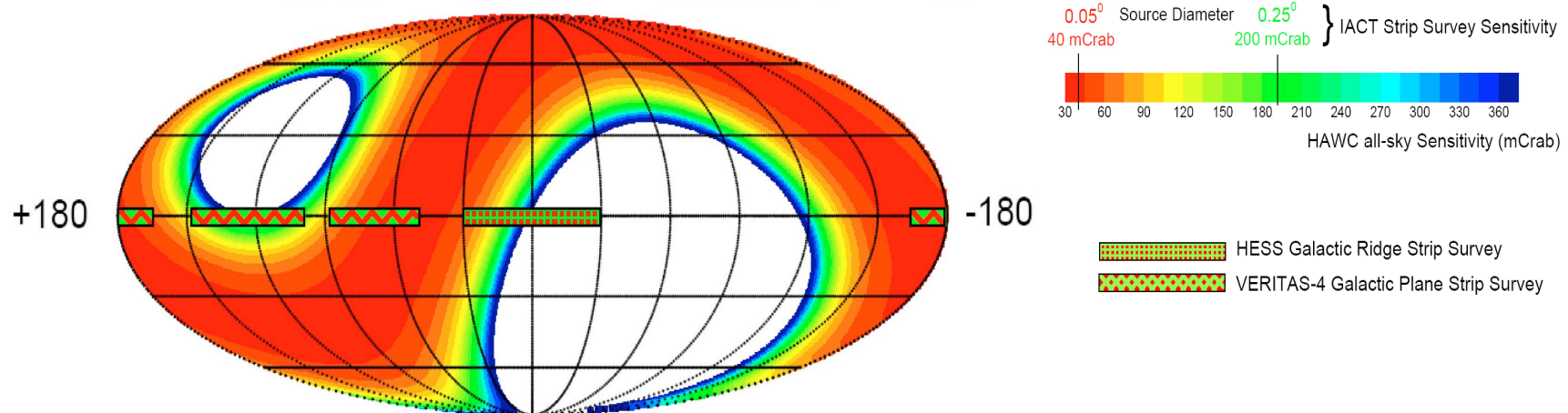



IV.- High Altitude Water Cherenkov (HAWC) Observatory: Second Generation (WCD)

HAWC Large field of view, continuously operating high energy gamma ray observatory (100 GeV to hundreds TeV). One of the primary goals of HAWC is to identify new TeV gamma-ray sources and extended measurements of known sources to higher energies. Spectra studies up to 10 TeV (e.g., SEDs), Monitoring (Transients, GRB, AGN), Large Scale (Anisotropy), Diffuse emission.

AIMS

- Provide an unbiased map of the TeV sky (2.5π sr/day)
- Study transient emission from sources like AGNs
- Search for 100 GeV emission from GRBs
- Measure the energy spectrum of Galactic sources up to the highest energies
- Measure diffuse emission between 1 and 100 TeV
- Study small and large scale anisotropy of cosmic rays at energies > 1 TeV
- Search for new physics at TeV energies
- Provide TeV alerts for other instruments

The HAWC Collaboration

- University of Maryland
- Los Alamos National Laboratory
- University of Wisconsin
- University of Utah
- Univ. of California, Irvine
- Michigan State University
- George Mason University
- University of New Hampshire
- Pennsylvania State University
- University of New Mexico
- Michigan Technological University
- NASA/Goddard Space Flight Center
- Georgia Institute of Technology
- University of Alabama
- The Ohio State University
- Colorado State University
- University of California Santa Cruz



USA

Instituto Nacional de Astrofísica, Óptica y Electrónica (INAOE)

Universidad Nacional Autónoma de México (UNAM)

Instituto de Física

Instituto de Astronomía

Instituto de Geofísica

Instituto de Ciencias Nucleares

Mexico



Benemérita Universidad Autónoma

Universidad Autónoma de Chiapas

Universidad Autónoma del Estado de Hidalgo

Universidad de Guadalajara

Universidad Michoacana de San Nicolás de Hidalgo

Centro de Investigación y de Estudios Avanzados

Universidad de Guanajuato

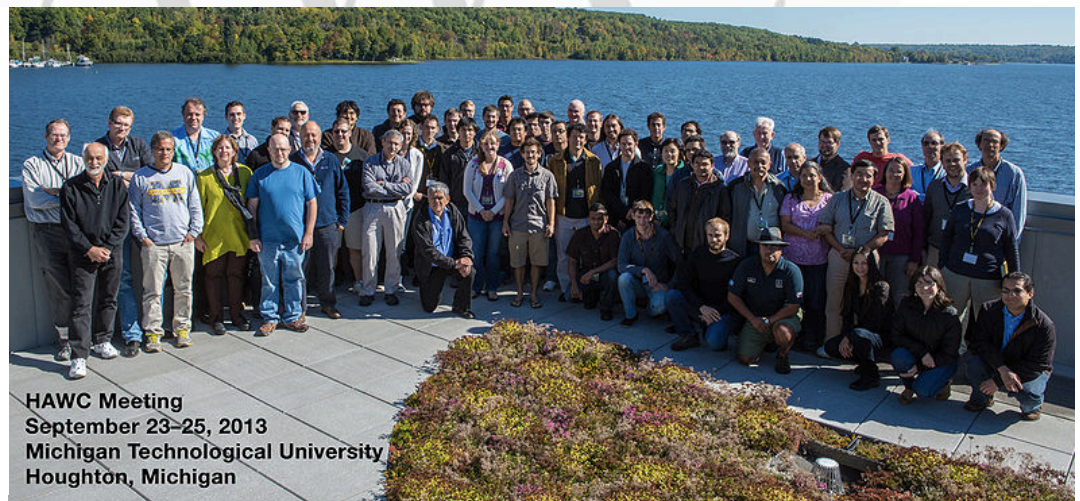

HAWC Meeting
September 23-25, 2013
Michigan Technological University
Houghton, Michigan

V.- High Altitude Water Cherenkov (HAWC); Design



300 hundred tanks (detectors) at completion, covering 20,000 m², 4100 m asl.

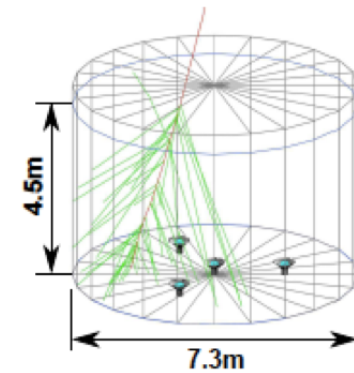

Each tank with 200,000 liters of ultra-pure water and 4 PMTs



Modular Construction, actual 111 detectors are operational

V.- High Altitude Water Cherenkov (HAWC); Design



Important Dates

12M USD project
funding began
Feb 2011

Operations with
100 water
Cherenkov
detectors in
Aug 2013

Observatory
complete in
Aug 2014

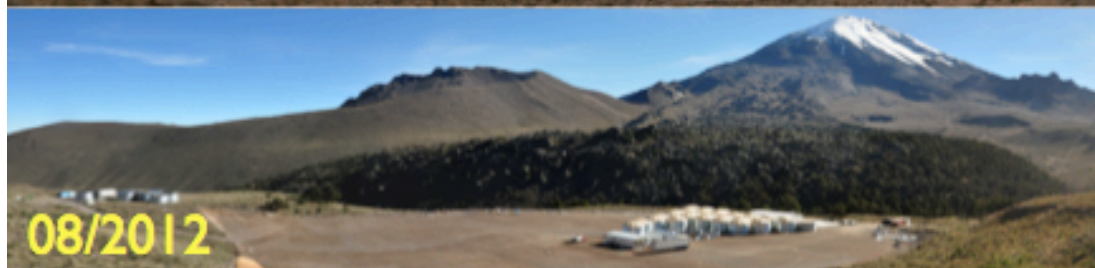

Adding 4th PMT in center of each Water Cherenkov Detector

- Higher quantum efficiency of 1.3x Milagro's PMTs
- Larger 10" diameter or 1.5x area of Milagro's PMTs
- Effectively $1.3 \times 1.5 = 2x$ Milagro's PMT

V.- High Altitude Water Cherenkov (HAWC); Electronics

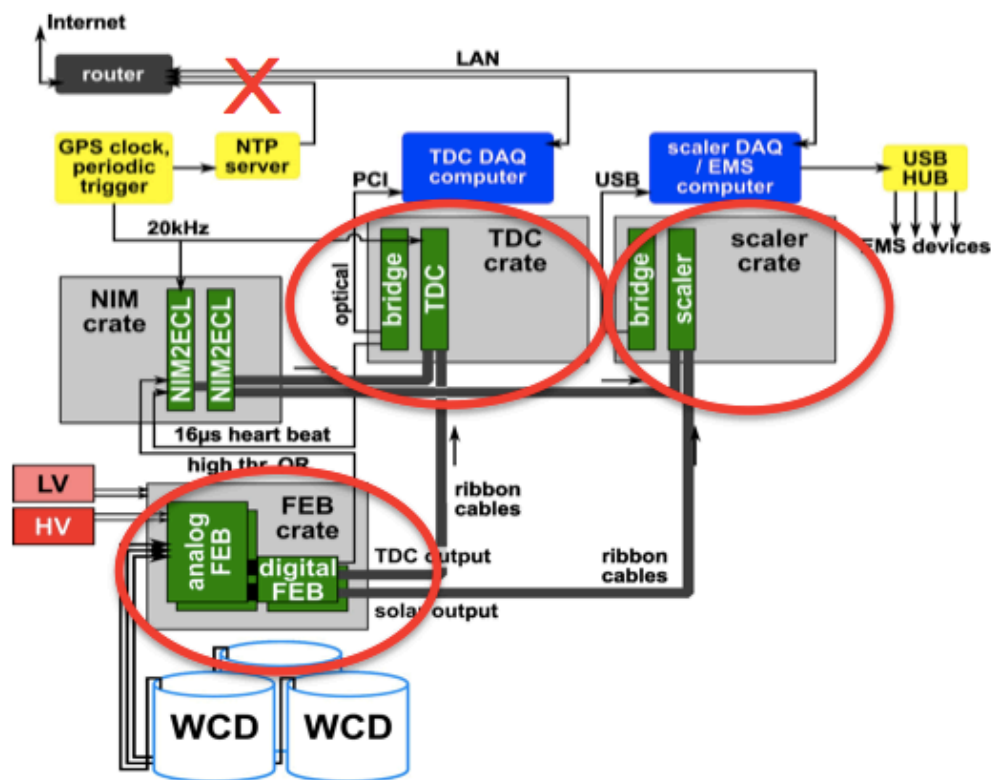

EMS records pressure, temp, water level

Scalers take single rates and are readout every 10 ms

TDC record the ToT of every signal above 1/4 and 5 single photo electrons ~30 kHz/PMT 11 MB/s to disk

Data stored in 8 TB portable disk arrays they are transported to UNAM read into the ICN cluster and mirrored to UMD 26 TB recorded during October

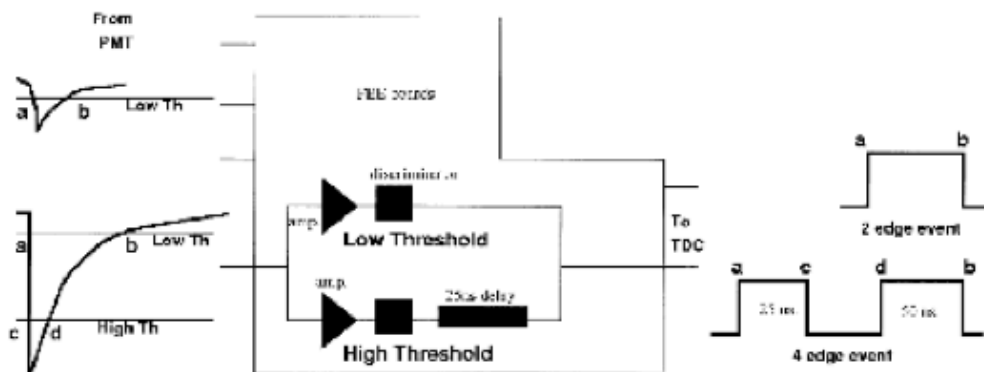

V.- High Altitude Water Cherenkov (HAWC); Electronics

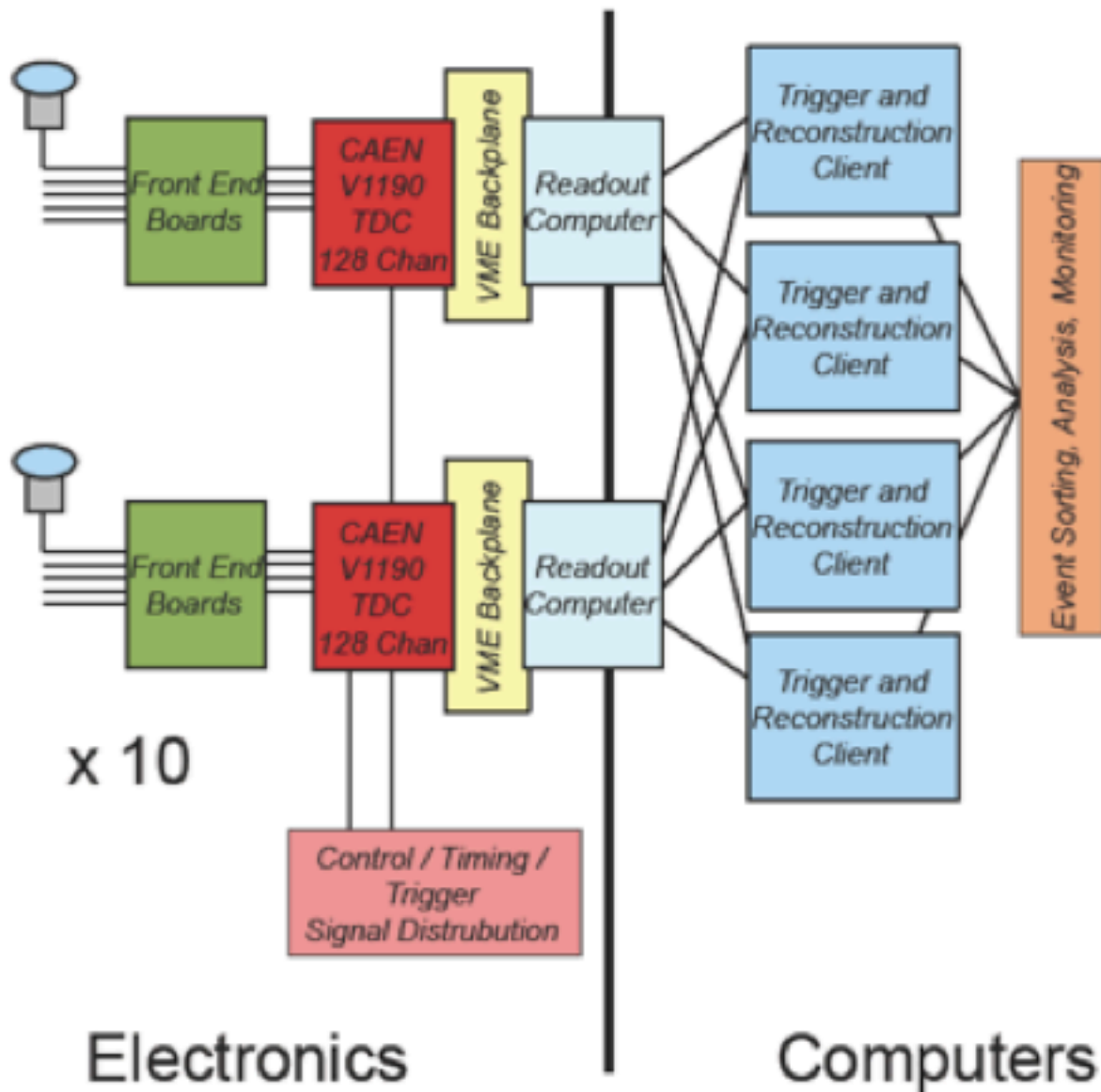

Recording all photoelectrons in all 1200 PMTs is 500 MB/sec = 40 TB/day

Requires distributed DAQ with events built in software.

Compress and process data to 20MB/sec within 1 day to create dataset of 3 PB after 5 years of operation.

V.- High Altitude Water Cherenkov (HAWC); Performance

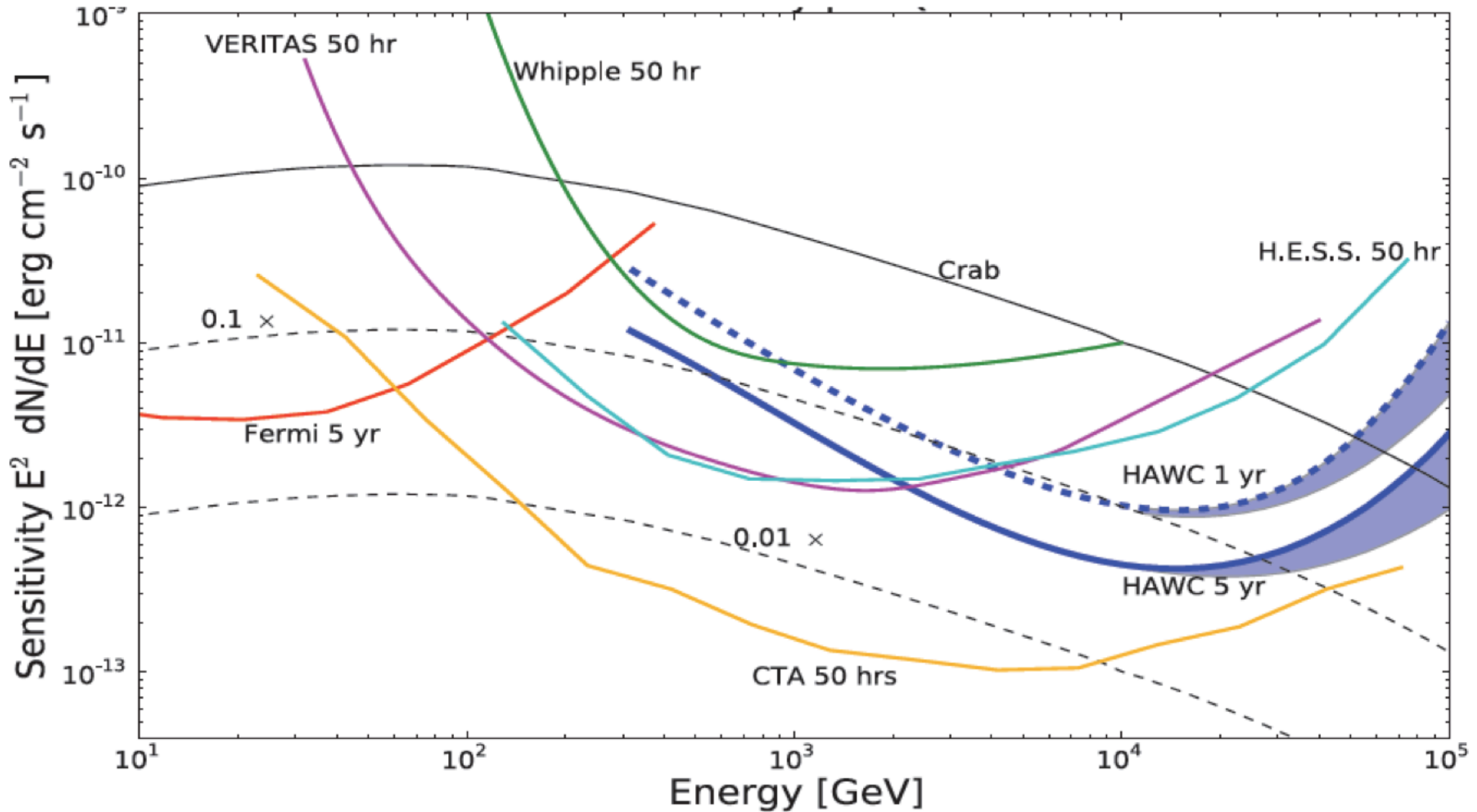

See: Abeysekara et al., “Sensitivity of the High Altitude Water Cherenkov Detector to Sources of Multi-TeV Gamma Rays”, *Astroparticle Physics*, accepted (arxiv: 1306.5800)

V.- High Altitude Water Cherenkov (HAWC); Performance

HAWC Performance at 2 TeV

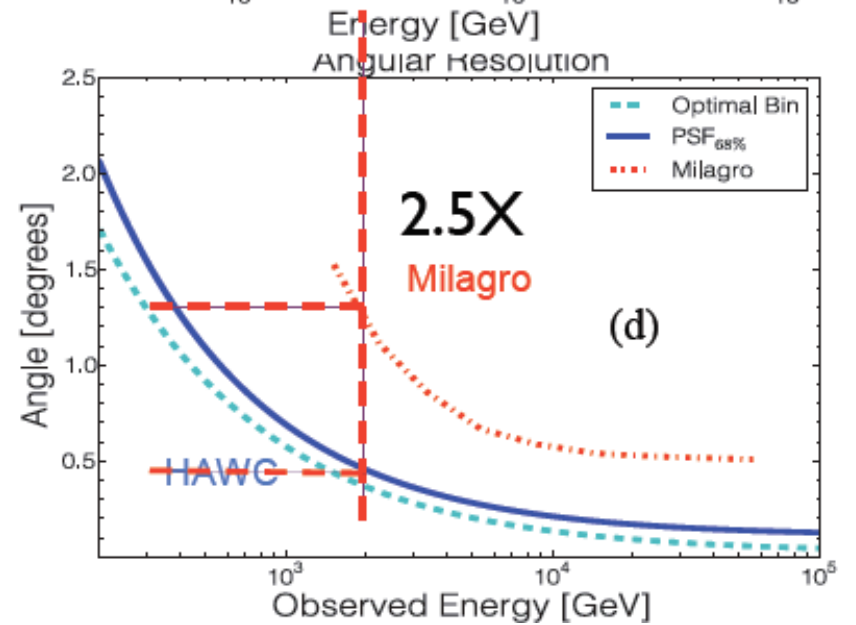
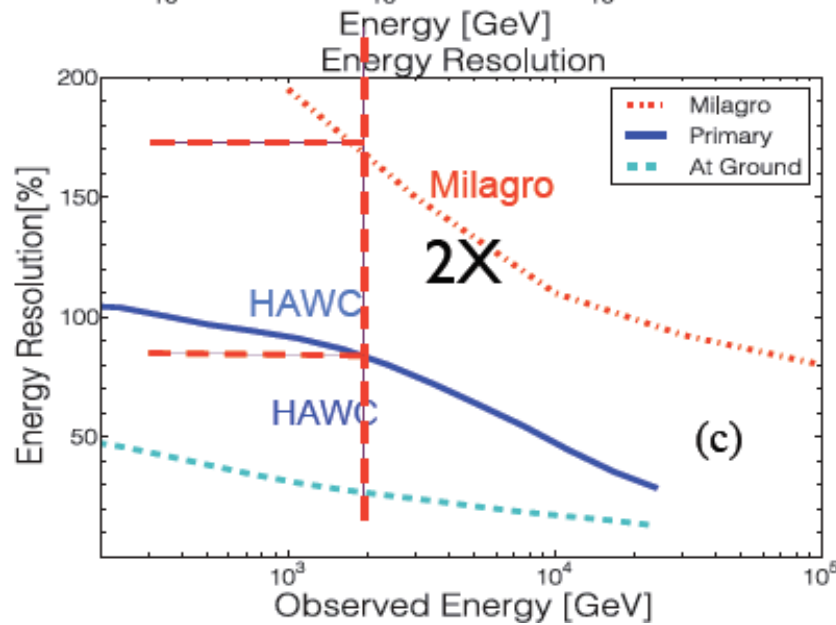
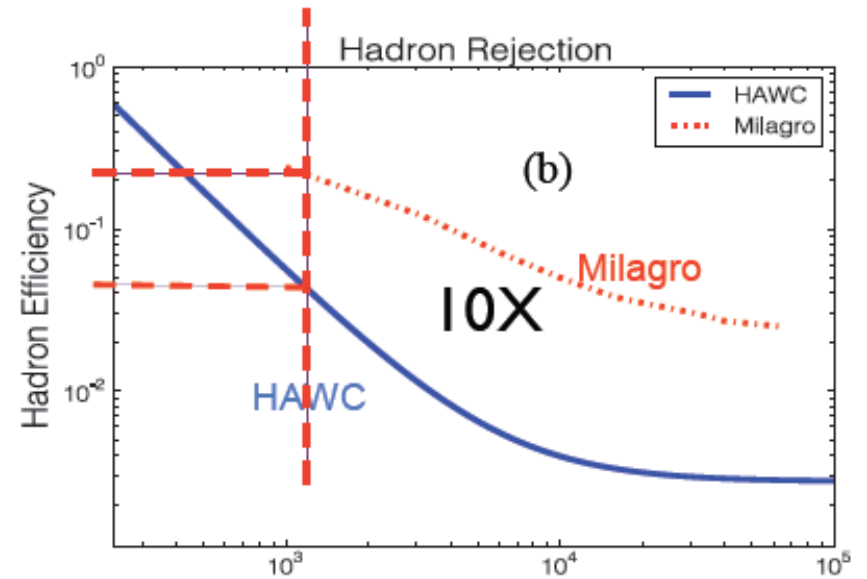
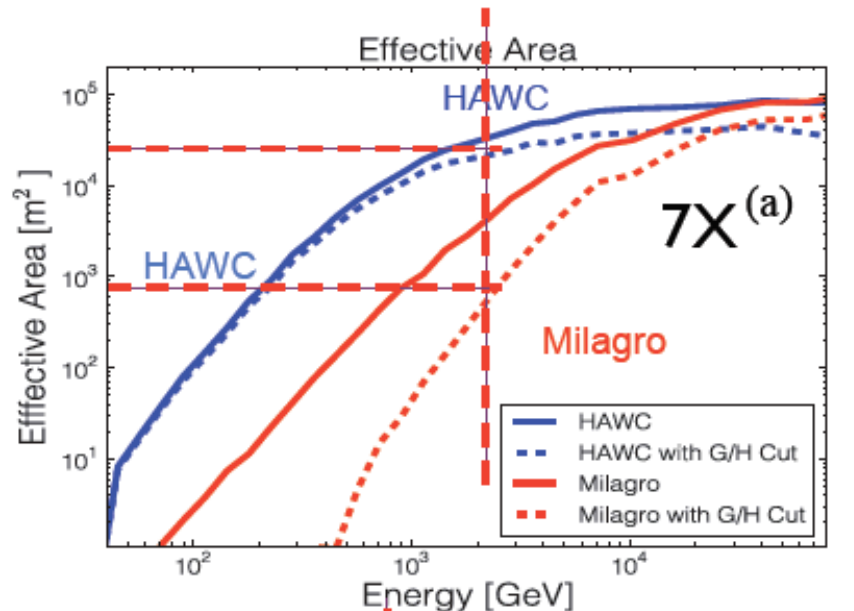

V.- High Altitude Water Cherenkov (HAWC); Performance

Better Gamma / Hadron Rejection than Milagro and ARGO- YBJ. Very important issue.

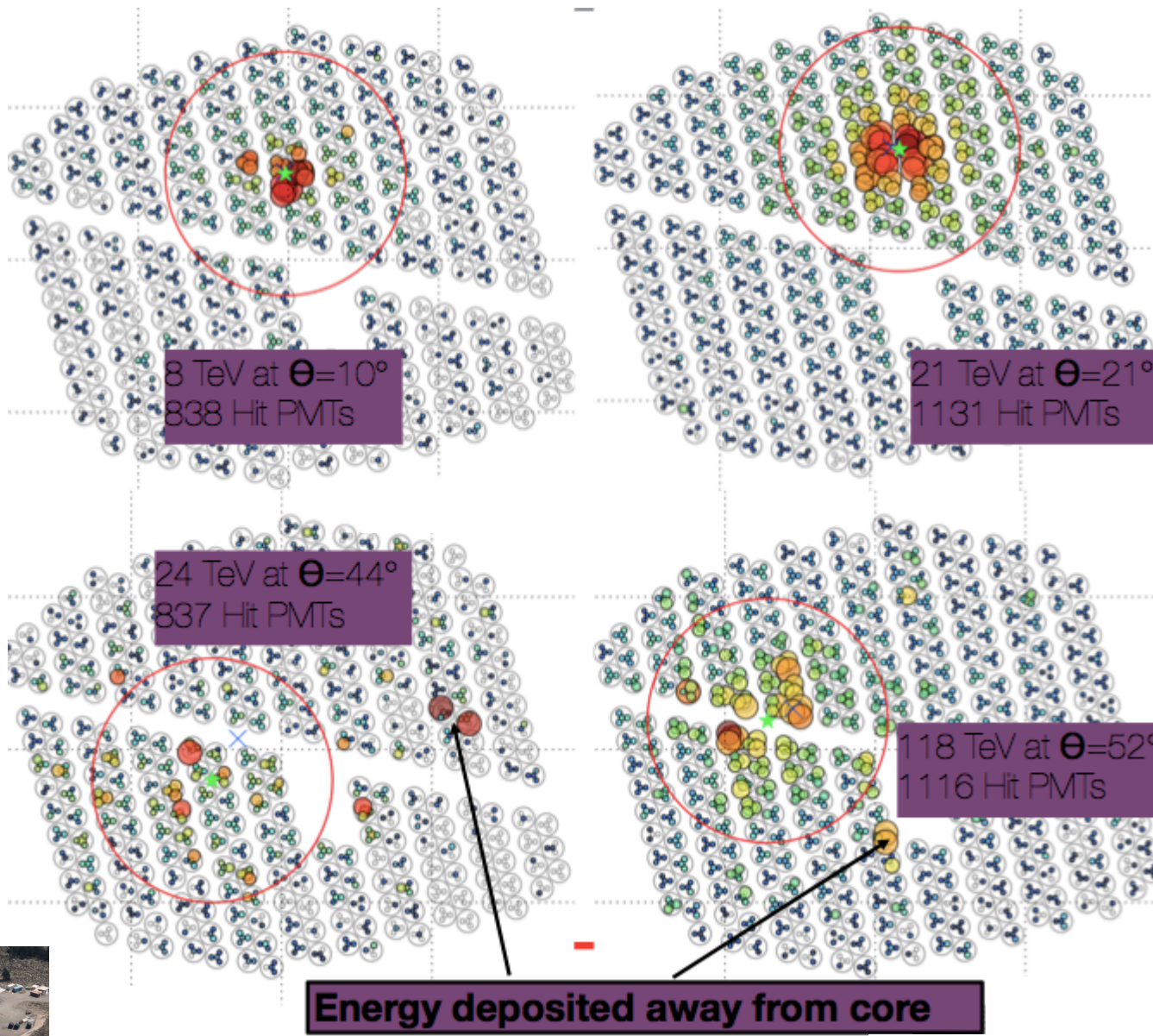

HAWC 30 (detectors) Full Moon



Cosmic rays are hampered by the Moon



Deficit of cosmic rays in the direction of the Moon

• Size of the deficit →

Angular Resolution

• Position of the deficit →

Pointing Error

Geomagnetic Field: positively charged particles deflected towards the West and negatively charged particles towards the East.



Ion spectrometer

$$\Delta\vartheta \approx \frac{1.6^\circ}{E(\text{TeV})}$$

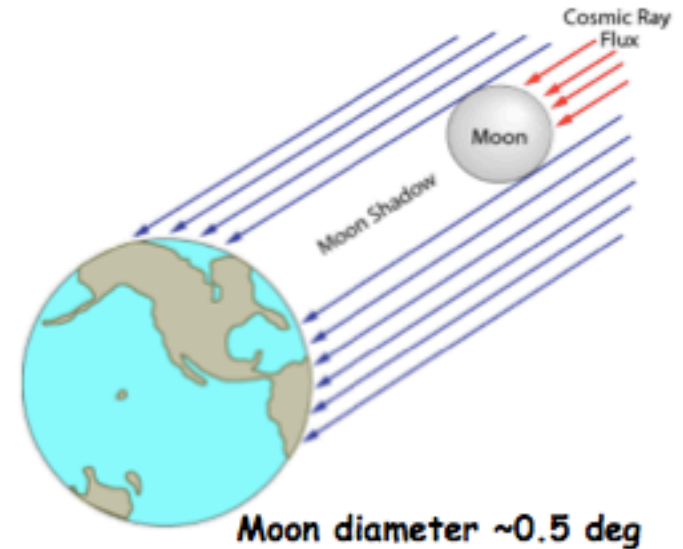

The observation of the Moon shadow can provide a direct check of the relation between size and primary energy: → **Energy Calibration**

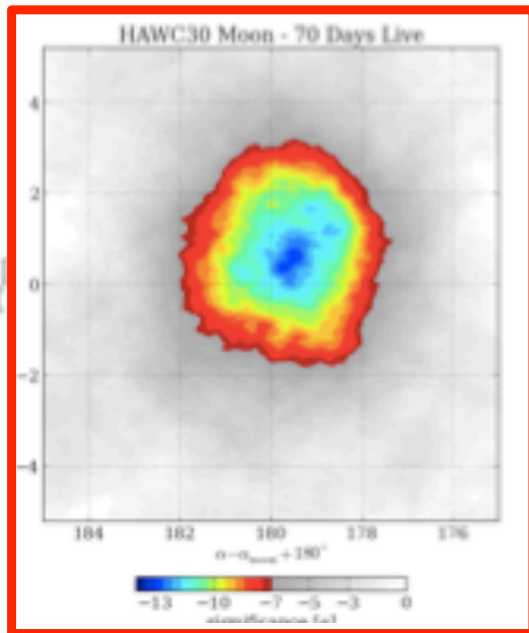
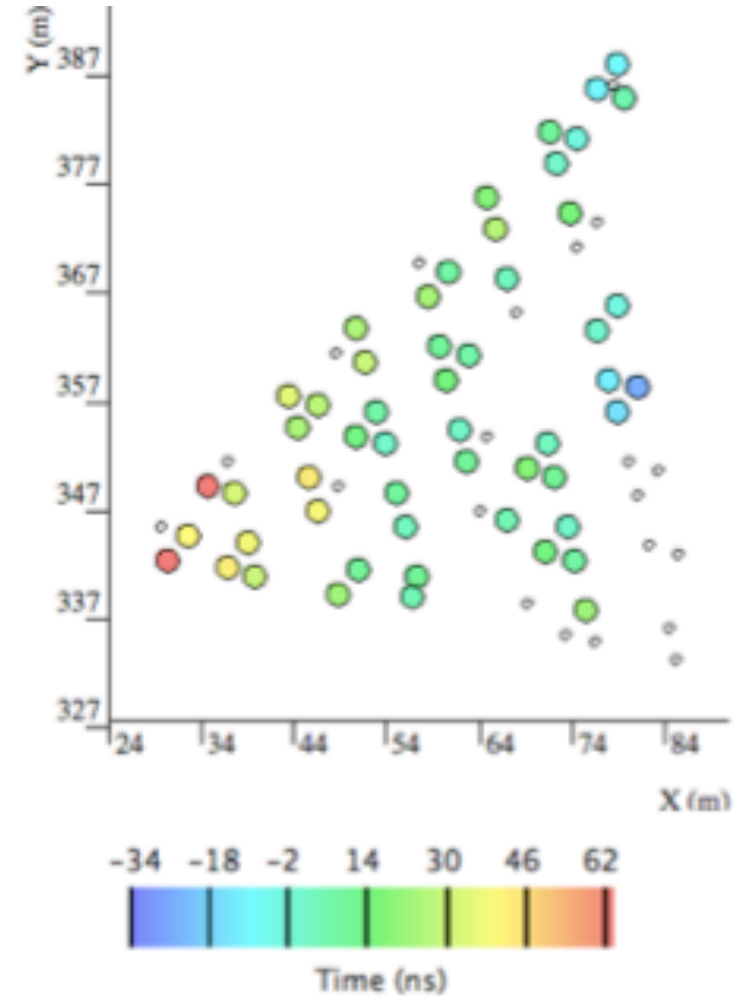
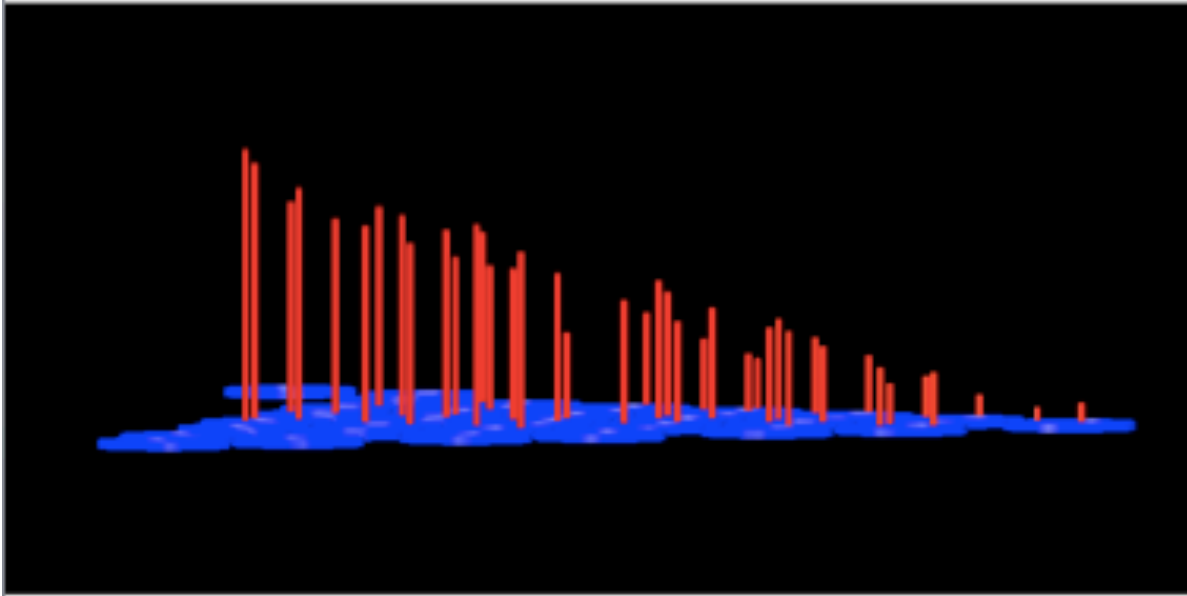

HAWC 30 Events and Observation of cosmic-ray shadow of Moon with 70 days of data

- HAWC science operations began Aug 1, 2013
- All data is reconstructed on site
- Site data shows evidence of gamma rays
 - 3.3 σ at Crab, 4.6 σ nearby
 - 5.4 σ at Mrk501, 5.7 σ nearby
- Triggered data being transferred via internet to UMD now
- Offline reconstruction beginning
- Full calibration soon
- Expect 111 WCDs have $\sim 5x$ sensitivity of Milagro and $\sim 1/3$ the full HAWC sensitivity

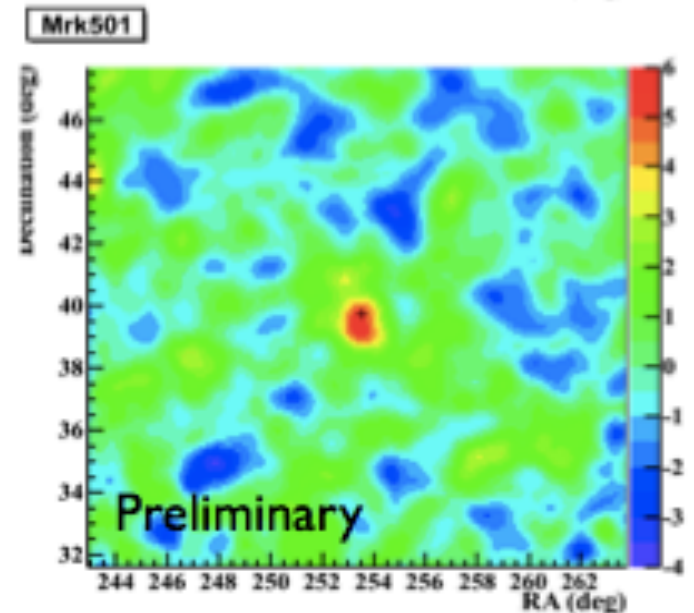
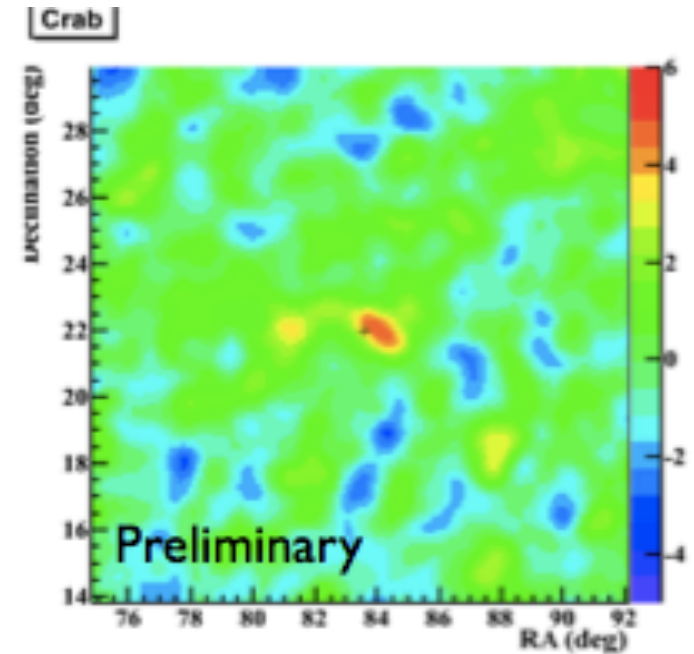

Unexpected Anisotropy of 10 TeV Cosmic Rays; Gyroradius of 10TeV proton in $2\mu\text{G}$ field is 1000 AU

Milagro + IceCube TeV Cosmic Ray Data (10° Smoothing)

Milagro:
Abdo, et al. PRL, 2009

IceCube
R. Abbasi, et al., ApJ 2011

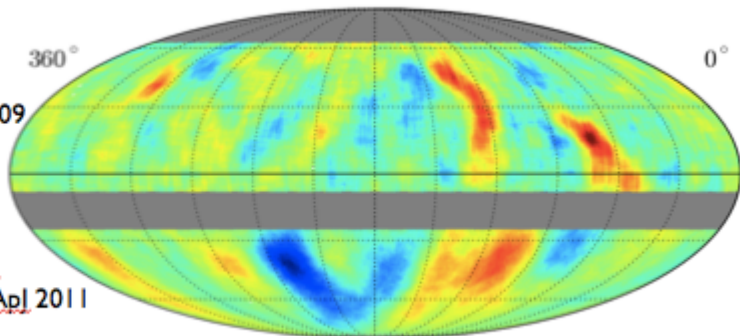

$n_{\text{Ch}} \geq 32$

Direct
integration

$2\text{hr} \geq dt \geq 1\text{hr}$

10° smoothing

Li/Ma signif.

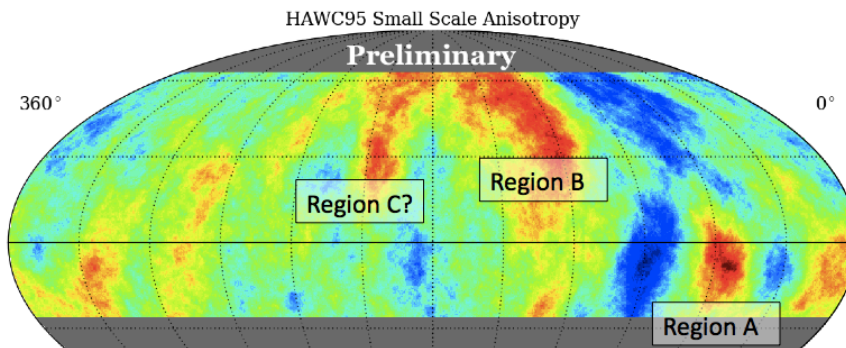

significance [σ]

Region A : 7.0 sigma
Region B : 5.5 sigma
Region C : 4.9 sigma

Pre-trial will be greater than 7 with another month of data.

Find post-trial with random data sets.

ARGO-YBJ

S. Vernetto et al., Proc. 31st ICRC, 2009

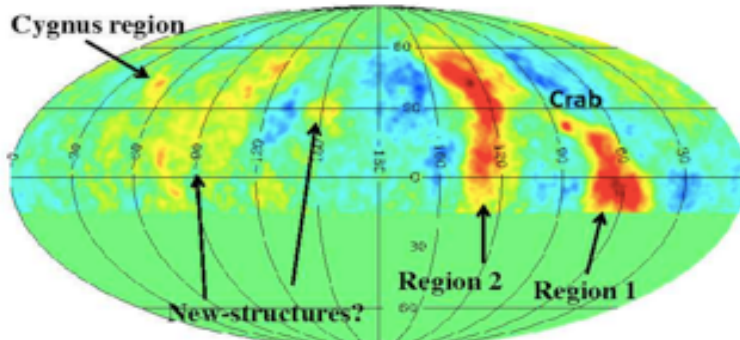

HAWC95 Small Scale Anisotropy

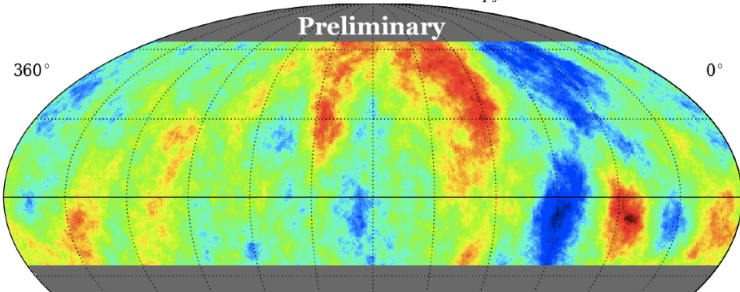

significance [σ]

Astroparticle Physics, in preparation

Point of Contact: Segev Benzvi and Dan Fiorino; University of Wisconsin

VI.- Preliminary Results

ARGO-YBG vs. HAWC 95

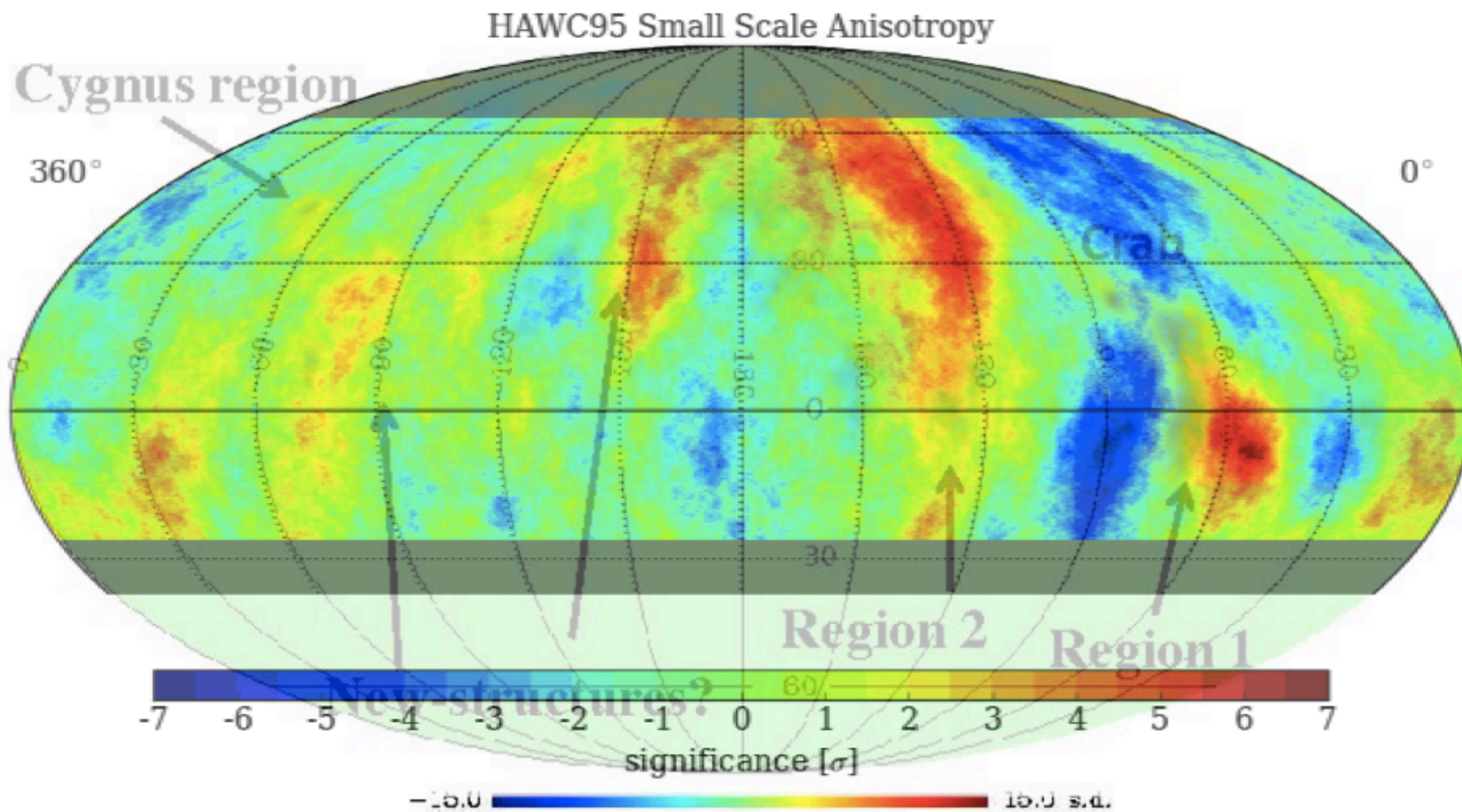

Astroparticle Physics, in preparation
Point of Contact: Segev Benzvi and Dan Fiorino; University of Wisconsin

GRB 130427A

- Brightest GRB detected in 30 years (2×10^{-3} erg/cm²)
- Highest energy photon ever recorded from a GRB - 94 GeV
- low redshift $z = 0.34$
- zenith angle at HAWC = 57° and setting (very bad)
- HAWC main DAQ was off, but PMT rates were recorded by the scalers DAQ

6 different time windows examined, no excess found (GCN circular 14549)
 would be seen at $\sim 5\sigma$ if it happened near zenith

For details see

D. Lennarz et al., Sensitivity of the HAWC Observatory to Gamma-ray Bursts Using the Scaler System, ICRC 2013

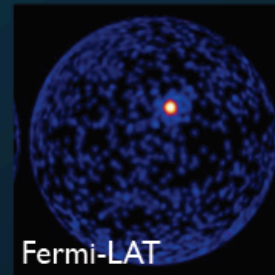

summed PMT rate and moving average

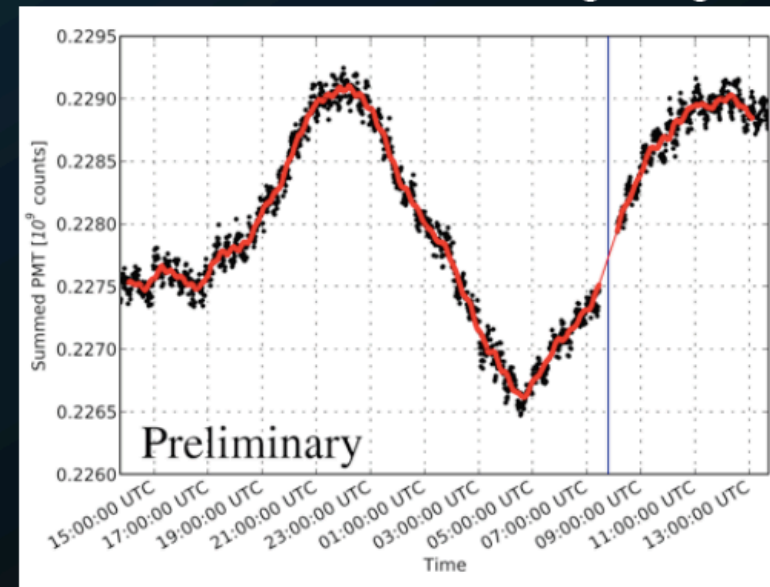

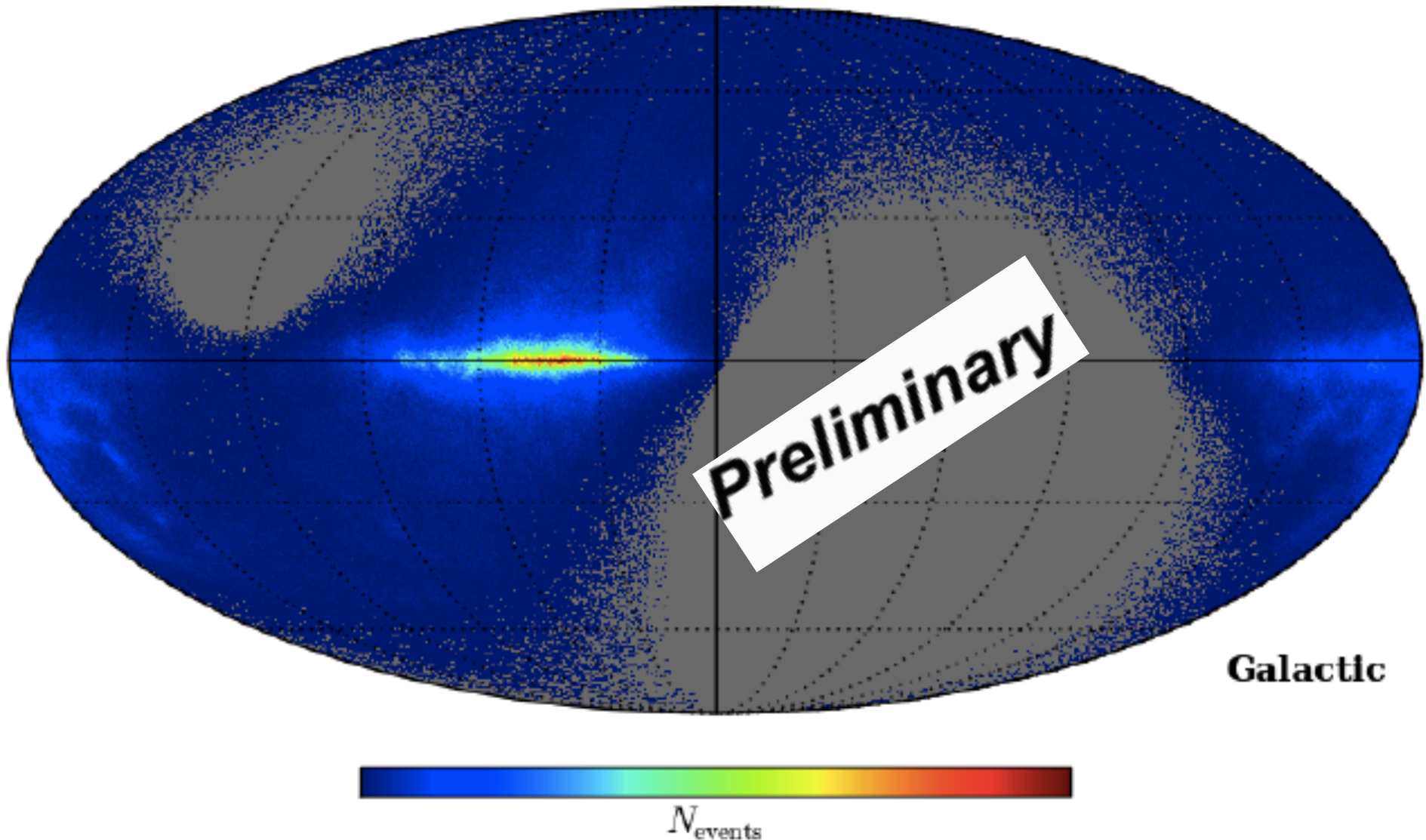

Paper to be published, See Huntemeyer et al., 2013, Proceedings of the ICRC 2013
Point of Contact: Petra Huntemeyer, Michele Hui, and Hugo Ayala (Michigan Tech, Houghton)

Mexican Group (IA-UNAM, UAIEH, U de G, ICN-UNAM) created to study supernova remnants (plerions and Pulsar Wind Nebula; see Ambrocio-Cruz & de la Fuente poster).

Focus in those Supernova Remnants reported by MILAGRO

Perform optical (Polarimetry and Fabry-Perot), X-Ray, and Gamma-Ray with HAWC. Contrasting between observations

Polarization can be produced by anisotropic radiation processes (Light scattering, Zeeman effect, Synchrotron emission, Dichroic absorption, birefringence); A more direct way to investigate the magnetic field configuration.

Multi-Wavelengths (MW) observations are useful to detect structures and bright features associated with the PWN, to confirm theoretical models associated with the nature of the emission, and determine regions of different emission (e.g., Radio; Synchrotron, and Gamma Rays; accelerated protons interacting with molecular clouds) in Supernova Remnants.

VII.- Future and Sinergy of HAWC with other experiments

Complements TeV atmospheric Cherenkov telescopes (which have <3 degree field of view and $<10\%$ duty factor)

Identifies new and flaring sources for follow up observation of morphology and sub TeV spectra

Extends TeV spectra to higher energies

Complements GeV All Sky Survey

Monitors 1000s of Fermi GeV sources at higher energies

Complements TeV neutrino observations

Identifies new and flaring TeV sources to improve the sensitivity and interpretation of blind searches

Complements Advanced LIGO

Simultaneous observations of nearby, short GRBs from ns-ns inspiral

THANK YOU!



**HAWC Meeting
September 23–25, 2013
Michigan Technological University
Houghton, Michigan**