

The ν -process in Core - Collapse Supernovae

A. Sieverding*, G. Martínez-Pinedo, K. Langanke, T. Marketin A. Heger

Y206

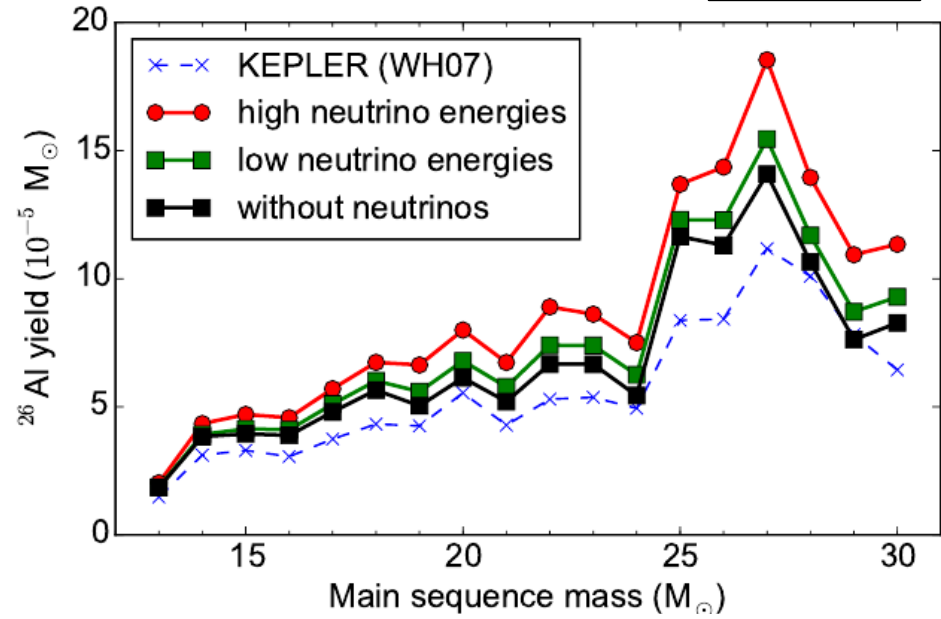
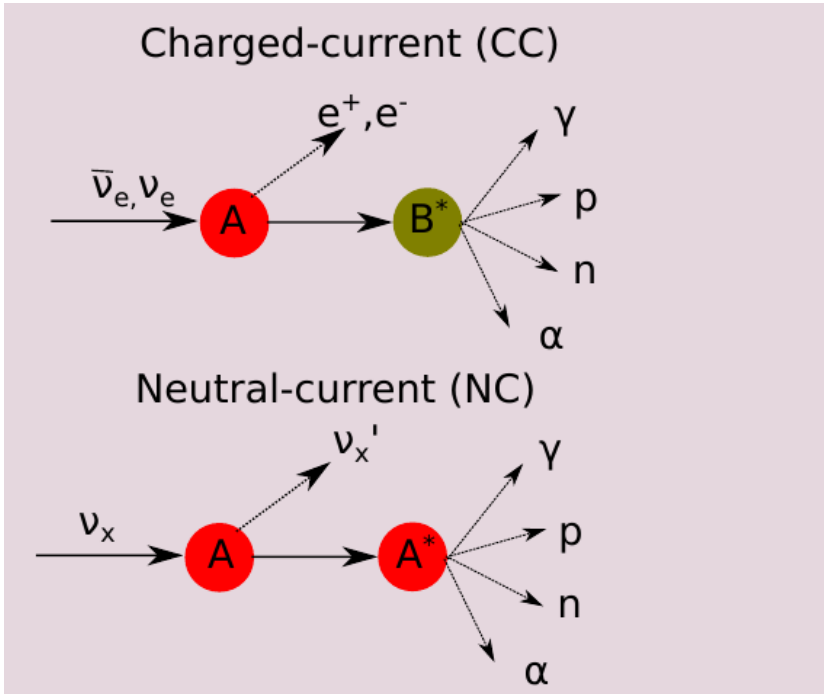

Nucleus	no ν	Low energies ¹	High energies ²
⁷ Li	0.001	0.07	0.91
¹¹ B	0.005	0.45	1.81
¹⁵ N	0.06	0.09	0.15
¹⁹ F	0.12	0.25	0.40
¹³⁸ La	0.12	0.86	1.70
¹⁸⁰ Ta	0.6	1.49	2.67

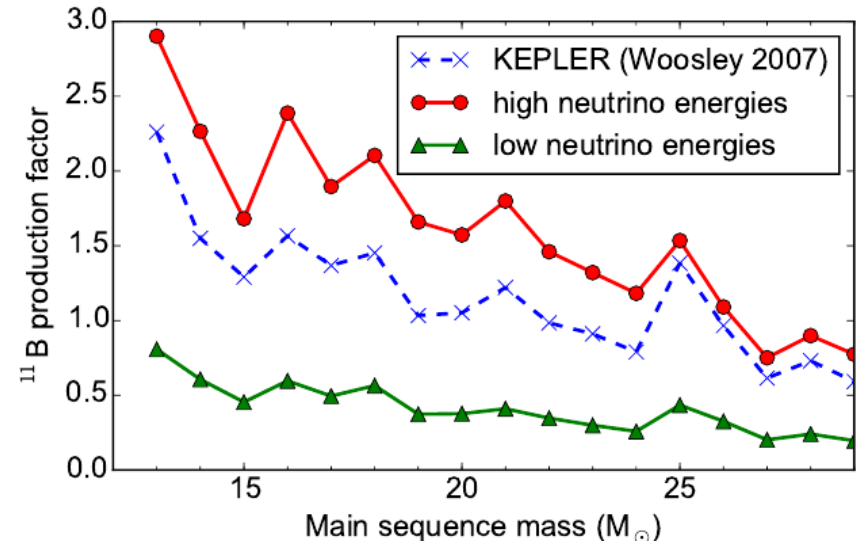

Effect of our improved understanding of the neutrino signal in **CCSNe** on the **neutrino-process during explosive nucleosynthesis!**